

# MODBUS AND BACNET COMMUNICATION INSTRUCTIONS

For Models: Crest FB/OF751 -  
6001, FCB1000-6000, &  
Regent IWH500-1000

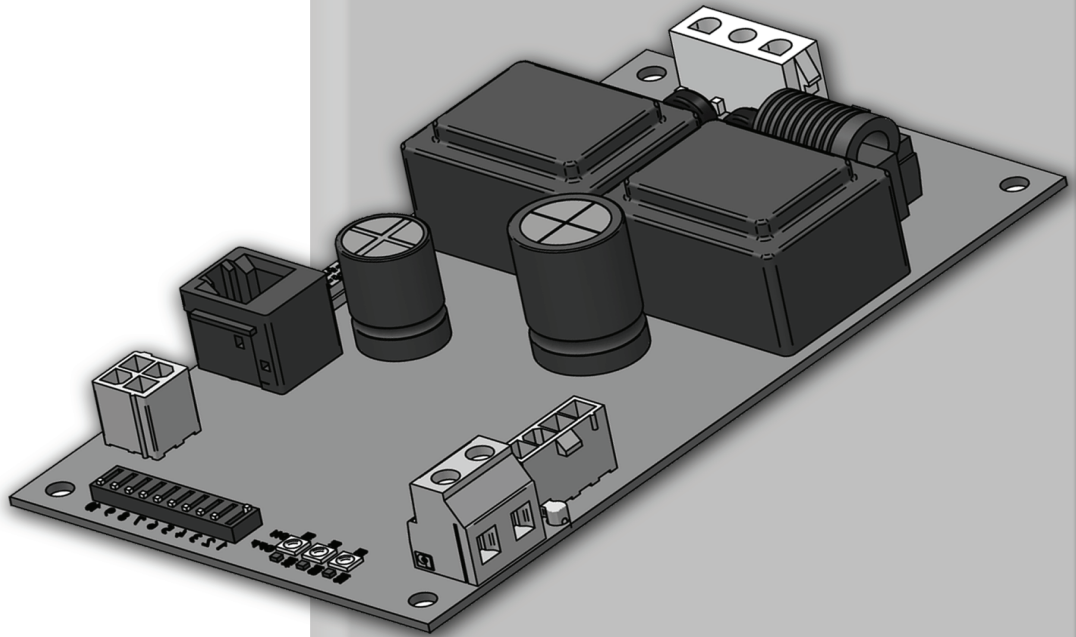

**⚠ WARNING**

This manual must only be used by a qualified heating installer / service technician. Read all instructions, including this manual, the Installation and Operation Manual, and the Service Manual, before installing. Perform steps in the order given. Failure to comply could result in severe personal injury, death, or substantial property damage.

# Contents

<p>1. INTRODUCTION</p> <p style="padding-left: 20px;">Definitions ..... 2</p> <p style="padding-left: 20px;">Minimum System Requirements..... 2</p> <p>2. INSTALLATION/REPLACEMENT</p> <p style="padding-left: 20px;">Crest and hellcat Models ..... 3</p> <p style="padding-left: 20px;">Regent Models..... 4-5</p> <p>3. MODBUS CONFIGURATION</p> <p style="padding-left: 20px;">Addressing ..... 6</p> <p style="padding-left: 20px;">Timing Specifications..... 7</p> <p style="padding-left: 20px;">Parity..... 7</p> <p style="padding-left: 20px;">Data Transmission Mode..... 7</p> <p style="padding-left: 20px;">ModBus Exception Codes ..... 9</p> <p>4. MODBUS MEMORY MAP FOR CREST AND HELLCAT</p> <p style="padding-left: 20px;">Crest and Hellcat Boiler Memory Map..... 10-11</p> <p style="padding-left: 20px;">Crest and Hellcat Configuration Bits ..... 12</p> <p>5. MODBUS MEMORY MAP FOR REGENT</p> <p style="padding-left: 20px;">Regent Memory Map..... 13-14</p> <p style="padding-left: 20px;">Regent Configuration Bits..... 15</p>	<p>6. BACNET CONFIGURATION ..... 16</p> <p style="padding-left: 20px;">Addressing..... 16</p> <p style="padding-left: 20px;">Timing Specifications..... 17</p> <p style="padding-left: 20px;">Communication Board Diagnostics ..... 17</p> <p>7. BACnet MEMORY MAP FOR CREST AND HELLCAT</p> <p style="padding-left: 20px;">Memory Map..... 18-20</p> <p>8. BACnet MEMORY MAP FOR REGENT</p> <p style="padding-left: 20px;">Memory Map..... 21-23</p> <p>9. WIRING REQUIREMENTS</p> <p style="padding-left: 20px;">Physical Wiring ..... 25</p> <p style="padding-left: 20px;">Typical Cascade System Wiring..... 26-34</p> <p>10. UNIT OPERATION FOR CREST AND HELLCAT</p> <p style="padding-left: 20px;">ModBus and BACnet Communications ..... 35-37</p> <p>11. UNIT OPERATION FOR REGENT</p> <p style="padding-left: 20px;">ModBus and BACnet Communications ..... 38-40</p> <p>12. RATE AND TEMPERATURE..... 41</p> <p>13. TROUBLESHOOTING..... 42-47</p> <p>Revision Notes ..... Back Cover</p>
--	---

## 1 Introduction

The information contained in this manual provides general guidelines for the implementation of ModBus / BACnet communication with the Lochinvar Crest boiler or Lochinvar Regent water heater.

All ModBus networks are implemented utilizing a master-slave arrangement where all appliances are slaves and the master is a building automation system capable of communicating over RS-485 serial connections. BACnet networks are implemented using a token passing process where multiple masters and slaves share a common RS-485 bus. The Lochinvar BACnet interface is a master only.

### Definitions

Abbreviation or Acronym	Meaning
ASCII	American Standard Code for Information Interchange
BACnet	A data communication protocol for Building Automation and Control Networks
BAS	Building Automation System
Baud (Baud Rate)	Number of data bits transmitted per second (bps)
EMS	Energy Management System
FDX	Full-Duplex
HDX	Half-Duplex
Hex	Hexadecimal Number (0 - 9, A - F)
I/O Box	Input/Output (I/O)
LSB	Least Significant Byte
ModBus®	A serial, half-duplex data transmission protocol developed by AEG Modicon
MSB	Most Significant Byte
RS232	A standard for serial, full-duplex (FDX) transmission of data based on the RS232 Standard
RS485	A standard for serial transmission of data based on the RS-485 Standard
RTU	Remote Terminal Unit

### Minimum System Requirements

- BAS system or computer with a serial or USB port with a converter to RS-485.  
Shielded twisted pair communication cable.

# 2 Installation/Replacement Procedure

## Installation/ Replacement Procedure - CREST AND HELLCAT ONLY

1. Turn OFF the main electrical power.
2. Turn OFF the main manual gas shutoff to the appliance.
3. Unplug the three (3) wire harnesses on the communication board (see FIG. 2-1).
4. Unscrew the four (4) mounting nuts on the communication board and set aside. Remove the communication board (see FIG. 2-2).
5. Replace / install the new communication board.
6. Replace the four (4) mounting nuts removed in Step 4.
7. Reconnect all three (3) wire harnesses unplugged in Step 3.
8. Turn on the main electrical power and the main manual gas shutoff to the appliance.
9. Configure the communication board and unit controls per this manual and resume operation.

Figure 2-1\_ Communication board

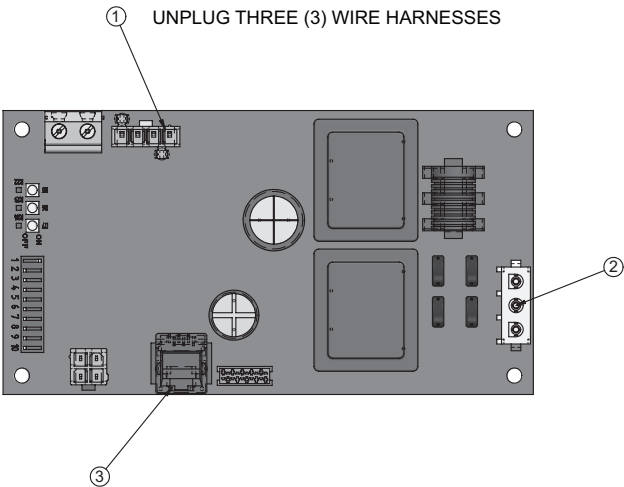

Figure 2-2\_ Control panel communication board

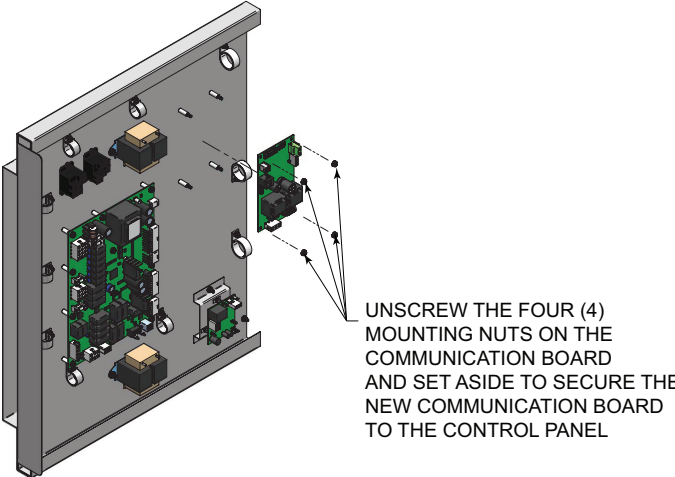
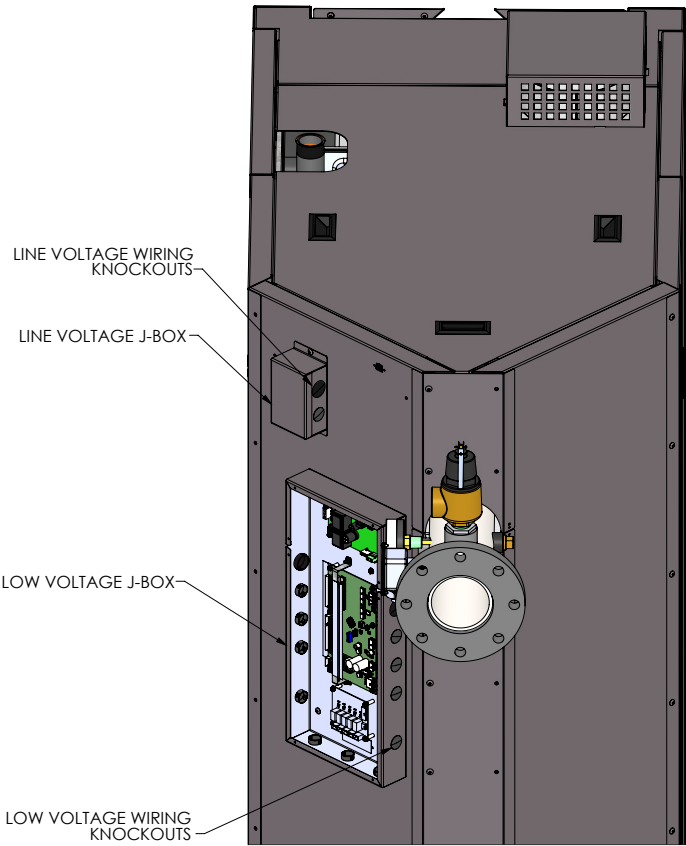

Figure 2-3\_ Hellcat - Routing field wiring



## 2 Installation/Replacement Procedure

### Installation/Replacement Procedure - REGENT ONLY

1. Turn OFF the main electrical power to the appliance.
2. Turn OFF the main manual gas shutoff to the appliance.
3. Remove the upper left side panel to access the low voltage panel (see FIG. 2-4).
4. Remove thumb nut and lift cover off the low voltage panel (see FIG. 2-5).
5. Assemble the four (4) aluminum spacers over the provided 6-32 threaded studs, mount board with connectors facing out, and tighten the four (4) lock nuts onto the board using a 5/16" socket or nut driver (see FIG. 2-6).
6. Extract the unused 3-pin Molex connector from plastic conduit clips in the center of the back panel. Remove protective cap and plug into power supply of MTR board at position MTR X1.
7. Detach the communication cable from the Comfort Control Board location CC X3 and plug it into the A1 female receptacle on the MTR harness (see FIG. 2-8). Then plug the MTR harness connector CC X3 into the CC board where the communication cable was.
8. Connect the single row 6-pin plug CC X12 into the provided location on the CC board and finally connect the remain plugs on the MTR harness into the provided locations on the MTR board, labeled MTR X4 and MTR X6 (see FIG. 2-7).

Figure 2-4\_Remove side panel

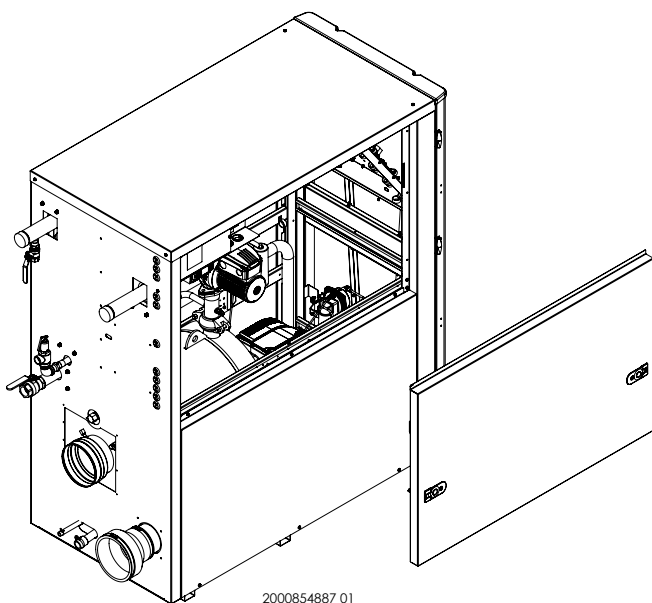

Figure 2-5\_Remove low voltage panel cover

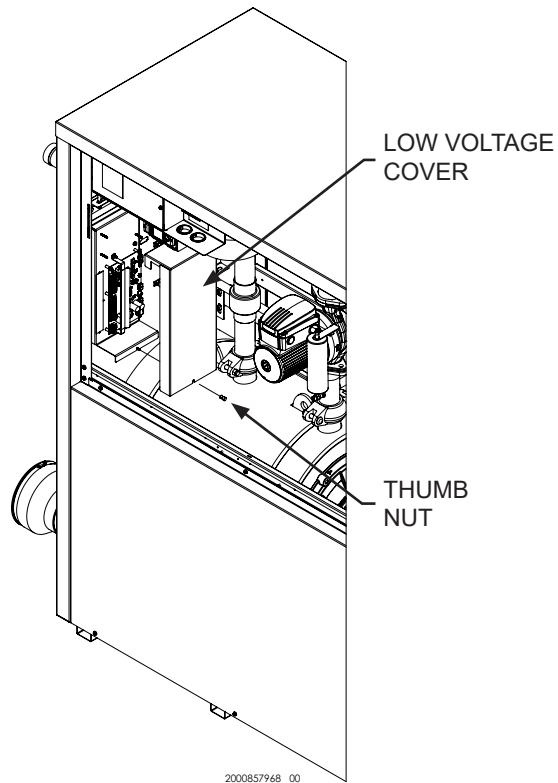
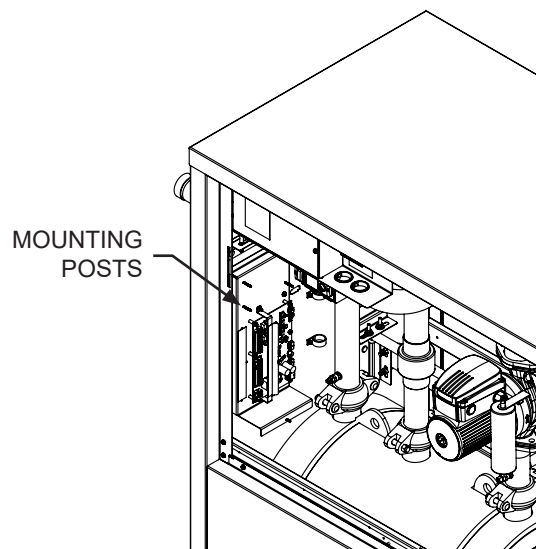

Figure 2-6\_Mount spacers, board, and lock-nuts



## 2 Installation/Replacement Procedure

Figure 2-7\_Connect power and MTR harness

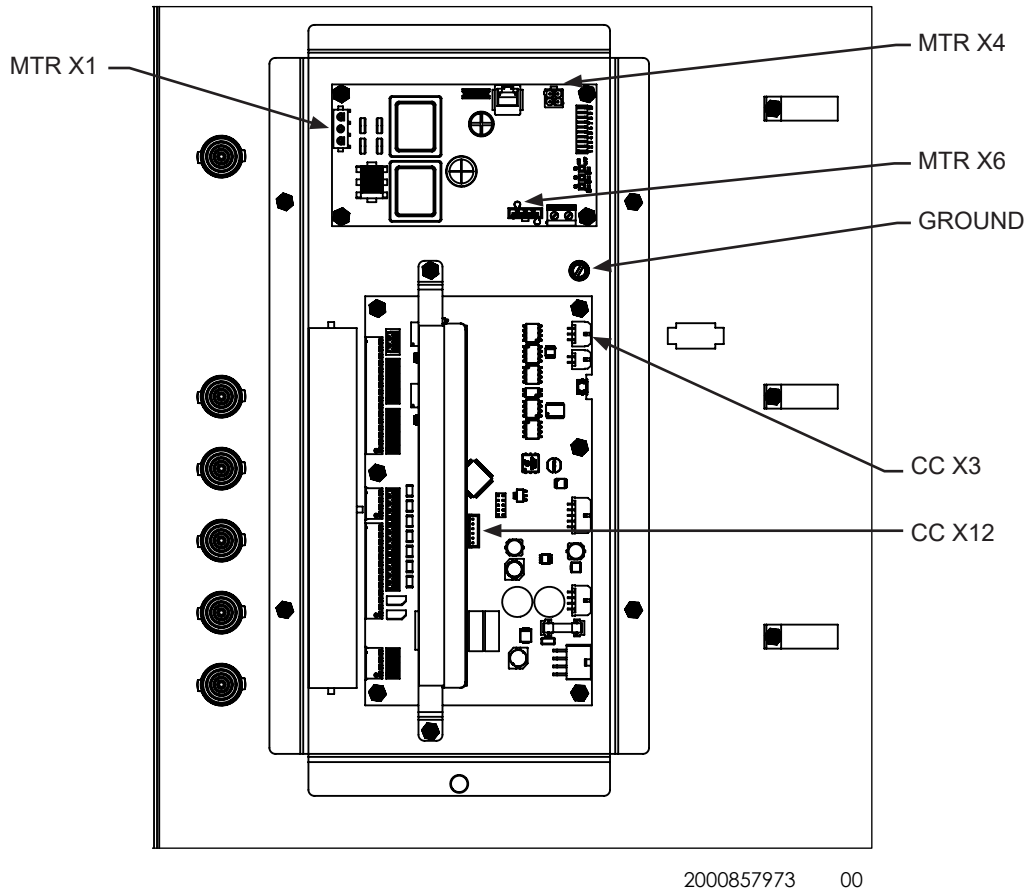
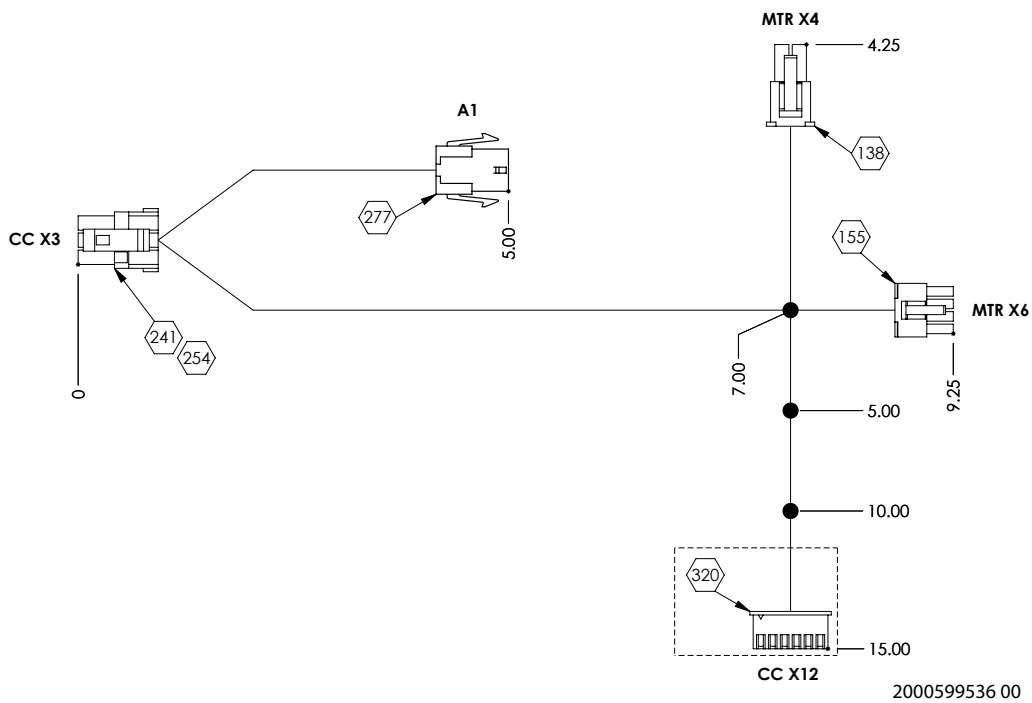

Figure 2-8\_MTR harness appearance



### 3 ModBus Configuration

The ModBus or BACnet communication board is equipped with a set of ten dip switches that are used to set the board configuration (address, baud rate, and parity settings). The first seven are used to set the address of each board. The eighth switch is used to select °C (off) or °F (on). The ninth is used to set the baud rate. The tenth is used to set the parity.

Figure 3-1\_ Communication Board

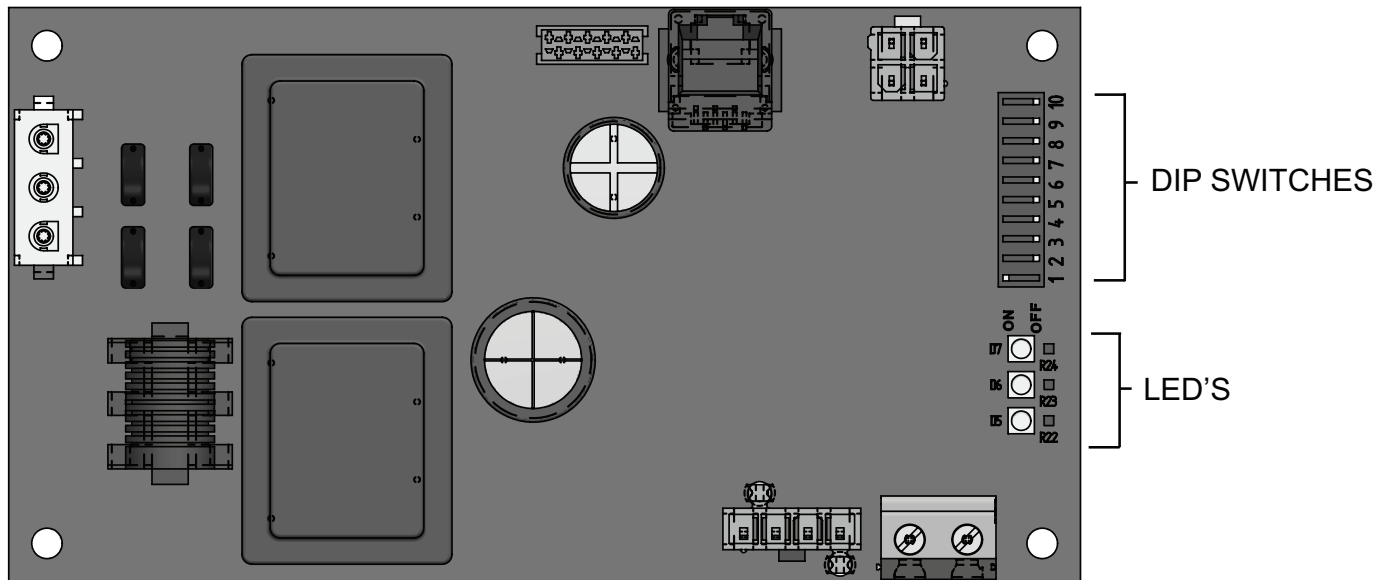

#### Addressing

The ModBus addressing space is comprised of 256 different addresses.

- 0 is reserved for broadcast messages from the master device
- 1 - 127 are free to use for each unique device
- 128 - 255 are reserved

To set the ModBus address the dip switches can be set in either the 0 position or the 1 position. For switches set to the 1 position their value will be added together to determine the address.

For each switch set to the 1 position it has the following value:

- Dip switch 1 = 1
- Dip switch 2 = 2
- Dip switch 3 = 4
- Dip switch 4 = 8
- Dip switch 5 = 16
- Dip switch 6 = 32
- Dip switch 7 = 64

Any dip switch set to 0 has a value equal to 0.

*Example:*

To set the address of the ModBus board to 50, dip switches 2, 5, and 6 have to be set to the 1 position. The address is determined by adding the values of all the dip switches together.

Address = Value of Dip switch 1 + Value of Dip switch 2 + Value of Dip switch 3 + Value of Dip switch 4 + Value of Dip switch 5 + Value of Dip switch 6 + Value of Dip switch 7

In this example:

$$\text{Address} = 0 + 2 + 0 + 0 + 16 + 32 + 0 = 50$$

#### °F/°C Setting

Accomplish the different selections with Dip switch #8 on the board. The OFF position displays Celcius while the ON position is Fahrenheit.

## 3 Modbus Configuration

### Timing Specifications

The baud rate for the ModBus board is selectable with Dip switch #9.

1 = 19200 bps

0 = 9600 bps

Each message is started by at least 3.5 character times of silence. The maximum delay between frames is 1.5 character times.

When the system supply temperature and/or tank temperature is provided by the BAS to the unit, it is critical that the temperature be updated every few seconds. If the unit does not receive updated temperatures within a timeout period, then the control will revert to using its own sensor inputs (if sensors are connected). For Crest models, the timeout is programmable by pressing the MAIN MENU >>SETUP>>BAS buttons. The timeout is adjustable between 5 and 120 seconds.

For Hellcat and Regent, the timeout is not programmable. The default timeout is 300 seconds.

For Crest, when the BAS is not providing either of these temperatures but still controlling the boiler (such as providing a modulation command), the BAS must refresh these commands at least every 4 minutes. If the commands are not refreshed, the boiler will revert to operating based on its own inputs.

For Regent, when the BAS is providing a set point command, the BAS must refresh this command at least every 4 seconds. If the command is not refreshed, the unit will revert to operating based on its own inputs.

### Parity

Parity is set by the position of Dip switch #10.

0 = No Parity

1 = Even Parity

If No Parity is selected there will be two stop bits, otherwise there will be one.

### Data Transmission Mode

Many ModBus bus master devices can be configured to transmit data in either ModBus RTU or ModBus ASCII modes. Since RTU messages can be formatted to use fewer data bits and are therefore more efficient, RTU has been chosen to be used with all Lochinvar ModBus communication. Please ensure that the master device is transmitting ModBus RTU.

### ModBus Board Diagnostics

The ModBus board is equipped with three LED's for visual diagnostics: Two yellow LED's and one green. One yellow LED (D5) is used to indicate transmission of data. The other yellow LED (D6) is used to indicate reception of data. The green LED (D7) is used to show internal faults.

Internal Faults:

Normal Operation = 1 second bright, 1 second dim

Controller Fault = Continuously on

No Burner Control Communication = 0.5 seconds on, 1.5 seconds off

No ModBus Communication = 1.5 seconds on, 0.5 seconds off

### ModBus Communication

The ModBus communication commands and exception codes that are supported by the ModBus communication board can be found in Sections 10 and 11 of this manual.

### 3 ModBus Configuration *(continued)*

#### ModBus Function Set

Function		Sub Function	HEX	Description
Dec	HEX	Dec		
1	01			Read Coil Status
2	02			Read Input Status
3	03			Read Holding Registers
4	04			Read Input Registers
5	05			Force Single Coil
6	06			Preset Single Register
7	07			Read Exception Status
8	08	0	00	Diagnostic - Return Query Data
		1	01	Diagnostic - Restart Communication
		2	02	Diagnostic - Return Diagnostic Register
		4	04	Diagnostic - Force Listen Mode
		10	0A	Diagnostic - Clear Counters and Diagnostic Registers
		11	0B	Diagnostic - Return Bus Message Count
		12	0C	Diagnostic - Bus Communication Error Count
		13	0D	Diagnostic - Bus Exception Error Count
		14	0E	Diagnostic - Return Slave Message Count
		15	0F	Diagnostic - Return Communication Error Count
		16	10	Diagnostic - Return Slave NAK Count
		17	11	Diagnostic - Return Slave Busy Count
		18	12	Diagnostic - Return Bus Character Overrun Count
		20	14	Diagnostic - Clear Overrun Counter and Flag
11	0B			Get Communication Event Counter
12	0C			Get Communication Event Log
15	0F			Write Multiple Coils
16	10			Write Multiple Registers
17	11			Report Slave ID
23	17			Read / Write Multiple Registers

## 3 ModBus Configuration

### ModBus Exception Codes

MODBUS / BACnet Exception Codes		
Code	Name	Meaning
01	ILLEGAL FUNCTION	The function code received in the query is not an allowable action for the server (or slave). This may be because the function code is only applicable to newer devices, and was not implemented in the unit selected. It could also indicate that the server (or slave) is in the wrong state to process a request of this type, for example because it is unconfigured and is being asked to return register values.
02	ILLEGAL DATA ADDRESS	The data address received in the query is not an allowable address for the server (or slave). More specifically, the combination of reference number and transfer length is invalid. For a controller with 100 registers, the PDU addresses the first register as 0, and the last one as 99. If a request is submitted with a starting register address of 96 and a quantity of registers of 4, then this request will successfully operate (address-wise at least) on registers 96, 97, 98, 99. If a request is submitted with a starting register address of 96 and a quantity of registers of 5, then this request will fail with Exception Code 0x02 "Illegal Data Address" since it attempts to operate on registers 96, 97, 98, 99 and 100, and there is no register with address 100.
03	ILLEGAL DATA VALUE	A value contained in the query data field is not an allowable value for server (or slave). This indicates a fault in the structure of the remainder of a complex request, such as that the implied length is incorrect. It specifically does NOT mean that a data item submitted for storage in a register has a value outside the expectation of the application program, since the MODBUS protocol is unaware of the significance of any particular value of any particular register.
04	SLAVE DEVICE FAILURE	An unrecoverable error occurred while the server (or slave) was attempting to perform the requested action.
05	ACKNOWLEDGE	Specialized use in conjunction with programming commands. The server (or slave) has accepted the request and is processing it, but a long duration of time will be required to do so. This response is returned to prevent a timeout error from occurring in the client (or master). The client (or master) can next issue a Poll Program Complete message to determine if processing is completed.
06	SLAVE DEVICE BUSY	Specialized use in conjunction with programming commands. The server (or slave) is engaged in processing a long -- duration program command. The client (or master) should re-transmit the message later when the server (or slave) is free.
08	MEMORY PARITY ERROR	Specialized use in conjunction with function codes 20 and 21 and reference type 6, to indicate that the extended file area failed to pass a consistency check. The server (or slave) attempted to read record file, but detected a parity error in the memory. The client (or master) can retry the request, but service may be required on the server (or slave) device.
0A	GATEWAY PATH UNAVAILABLE	Specialized use in conjunction with gateways, indicates that the gateway was unable to allocate an internal communication path from the input port to the output port for processing as the request. Usually means that the gateway is misconfigured or overloaded.
0B	GATEWAY TARGET DEVICE FAILED TO RESPOND	Specialized use in conjunction with gateways, indicates that no response was obtained from the target device. Usually means that the device is not present on the network.

## 4 ModBus Memory Map for Crest and Hellcat

### Primary Data Tables

Table	Data Type	Read / Write
Discrete Inputs	Single Bit	Read Only
Coils	Single Bit	Read / Write
Input Registers	16-Bit Word	Read Only
Holding Registers	16 Bit Word	Read / Write

### Memory Map

Coils						
Address	Description	Default	Unit	Min.	Max.	Resolution
00001	Boiler Enable	0	1=ON / 0=OFF	0	1	1
00005	Tank Thermostat	0	1=ON / 0=OFF	0	1	1
Discrete Inputs						
10001	Manual Reset High Limit	0	1=ON / 0=OFF	0	1	1
10002	Flow Switch	0	1=ON / 0=OFF	0	1	1
10003	Gas Pressure Switch	0	1=ON / 0=OFF	0	1	1
10004	Louver Proving Switch	0	1=ON / 0=OFF	0	1	1
10005	Blower Proving Switch 1* (not used on FB/OF 751-3001)	0	1=ON / 0=OFF	0	1	1
10006	Blocked Drain Switch	0	1=ON / 0=OFF	0	1	1
10008	Flame 1	0	1=ON / 0=OFF	0	1	1
10009	Enable*	0	1=ON / 0=OFF	0	1	1
10010	Tank Thermostat*	0	1=ON / 0=OFF	0	1	1
10011	Blocked Flue	0	1=ON / 0=OFF	0	1	1
10018	Internal LWCO **	0	1=ON / 0=OFF	0	1	1
10019	Gas Pressure Switch 2 **	0	1=ON / 0=OFF	0	1	1
10021	Flue Damper Proving Switch	0	1=ON / 0=OFF	0	1	1
10023	Flame 2	0	1=ON / 0=OFF	0	1	1
10026	Enable**	0	1=ON / 0=OFF	0	1	1
10030	Tank Thermostat**	0	1=ON / 0=OFF	0	1	1
10033	Run-time Contacts	0	1=ON / 0=OFF	0	1	1
10034	Alarm Contacts	0	1=ON / 0=OFF	0	1	1
10035	SH Pump	0	1=ON / 0=OFF	0	1	1
10036	HWG Pump	0	1=ON / 0=OFF	0	1	1
10037	Louver Relay	0	1=ON / 0=OFF	0	1	1
10038	Gas Valve 1	0	1=ON / 0=OFF	0	1	1
10039	System Pump	0	1=ON / 0=OFF	0	1	1
10044	Vent Damper Relay	0	1=ON / 0=OFF	0	1	1
10046	Gas Valve 2	0	1=ON / 0=OFF	0	1	1
10049	Blower #1 Power	0	1=ON / 0=OFF	0	1	1
10050	Blower #2 Power* (Older, dual fan models only)	0	1=ON / 0=OFF	0	1	1
10051	Spark Igniter	0	1=ON / 0=OFF	0	1	1
10052	Air Valve Trigger	0	1=ON / 0=OFF	0	1	1
10053	Air Valve Proving* (not used on FB/OF 4001-6001, can be used for FCB)	0	1=ON / 0=OFF	0	1	1

\* Crest Models FB/OF1501 - 6001 Only \*\*Crest FCB1000-6000 Only

## 4 ModBus Memory Map for Crest and Hellcat

Input Registers						
Address	Description	Default	Unit	Min.	Max.	Resolution
30001	Discrete Inputs 1 - 16	0	NA	0	65535	1
30002	Discrete Inputs 17 - 32	0	NA	0	65535	1
30003	Discrete Inputs 33 - 48	0	NA	0	65535	1
30004	System / Cascade Setpoint	0	°C	0	130	0.5
30005	System Pump Speed In	0	%	0	100	1
30006	Cascade Total Power	0	%	100	800	1
30007	Cascade Current Power	0	%	0	800	1
30008	Outlet Setpoint	0	°C	0	130	0.5
30009	Outlet Temperature	0	°C	0	130	0.1
30010	Inlet Temperature	0	°C	-20	130	0.1
30011	Flue Temperature	0	°C	-20	130	0.1
30012	Firing Rate	0	%	0	100	1
30013	Boiler Pump Speed Out	0	%	0	100	1
30014	Boiler Status Code	0	NA	0	65535	1
30015	Boiler Blocking Code	0	NA	0	65535	1
30016	Boiler Lockout Code	0	NA	0	65535	1
30019	Air Damper Target Angle**	0	NA	0	65535	1
30020	Gas Damper Target Angle**	0	NA	0	65535	1
30021	Fan Speed Target**	0	NA	0	65535	1
30023	O2 Sensor Status **	0	NA	0	65535	1
30024	Current Trim Factor **	0	NA	0	65535	1
30025	Barometer **	0	NA	0	65535	1
30026	Discrete Inputs 49 - 64	0	NA	0	65535	1
30027	Lock-out Error Leader	0	NA	0	65535	1
30028	Lock-out Error Member 1	0	NA	0	65535	1
30029	Lock-out Error Member 2	0	NA	0	65535	1
30030	Lock-out Error Member 3	0	NA	0	65535	1
30031	Lock-out Error Member 4	0	NA	0	65535	1
30032	Lock-out Error Member 5	0	NA	0	65535	1
30033	Lock-out Error Member 6	0	NA	0	65535	1
30034	Lock-out Error Member 7	0	NA	0	65535	1
30036	Flame 1 **	0	NA	0	65535	1
30037	Flame 2 **	0	NA	0	65535	1
30038	Correct O2 Reading **	0	NA	0	65535	1
Holding Registers						
40001	Configuration	0	NA	0	65535	1
40002	Coils	0	NA	0	65535	1
40003	0-10 Volt Input / Rate Command / Setpoint Command	0	%	0	100	1
40004	Tank Setpoint	0	°C	0	87,5	0.5
40005	Tank Temperature	0	°C	-20	130	0.1
40006	Outdoor Temperature	0	°C	-40	60	0.1
40007	System Supply Temperature	0	°C	-20	130	0.1
40008	System Return Temperature	0	°C	-20	130	0.1

\* Crest Models 1501 - 6001 Only \*\*Crest Models FCB1000-6000

## 4 ModBus Memory Map for Crest and Hellcat

### Configuration Bits

Address 40001 contains configuration bits sent from the BAS to the boiler. These bits tell the boiler to use its own internal inputs, or inputs from the BAS. When a bit is set to 1, the boiler will ignore the corresponding value contained internally, and expect the BAS to write that value into the Holding Registers. The configuration bits are as follows:

- Bit 0 (LSB): Boiler Enable
- Bit 1: Tank Thermostat
- Bit 2: Rate Command / 10 - 10V Input / Setpoint Command
- Bit 3: Tank Setpoint
- Bit 4: System Supply Temperature
- Bit 5: Outdoor Temperature
- Bit 6: Tank Temperature
- Bit 7: System Return Temperature
- Bit 8 - 15: Not Used (Default = 0)

## 5 ModBus Memory Map for Regent

### Primary Data Tables

Table	Data Type	Read / Write
Discrete Inputs	Single Bit	Read Only
Coils	Single Bit	Read / Write
Input Registers	16-Bit Word	Read Only
Holding Registers	16 Bit Word	Read / Write

### Memory Map

Coils						
Address	Description	Default	Unit	Min.	Max.	Resolution
00005	DHW Thermostat	0	1=ON / 0=OFF	0	1	1
Discrete Inputs						
10001	Hex Door Temperature Switch / MRHL	0	1=ON / 0=OFF	0	1	1
10002	Flow Switch	0	1=ON / 0=OFF	0	1	1
10003	Gas Pressure Switch	0	1=ON / 0=OFF	0	1	1
10004	Louver Proving Switch	0	1=ON / 0=OFF	0	1	1
10005	Proof of Closure	0	1=ON / 0=OFF	0	1	1
10006	Blocked Drain Switch	0	1=ON / 0=OFF	0	1	1
10008	Flame 1	0	1=ON / 0=OFF	0	1	1
10011	Blocked Vent Switch	0	1=ON / 0=OFF	0	1	1
10019	Gas Pressure Switch 2	0	1=ON / 0=OFF	0	1	1
10021	Flue Damper Proving Switch	0	1=ON / 0=OFF	0	1	1
10023	Flame 2	0	1=ON / 0=OFF	0	1	1
10030	DHW Thermostat	0	1=ON / 0=OFF	0	1	1
10033	Run-time Contacts	0	1=ON / 0=OFF	0	1	1
10034	Alarm Contacts	0	1=ON / 0=OFF	0	1	1
10035	Internal Circulation Pump	0	1=ON / 0=OFF	0	1	1
10036	Cascade Isolation Valve	0	1=ON / 0=OFF	0	1	1
10038	Gas Valve 1	0	1=ON / 0=OFF	0	1	1
10041	Building Recirculation Pump	1	1=ON / 0=OFF	0	1	1
10044	Vent Damper Relay	0	1=ON / 0=OFF	0	1	1
10049	Blower #1 Power	0	1=ON / 0=OFF	0	1	1
10051	Spark Igniter	0	1=ON / 0=OFF	0	1	1
10052	Air Valve Trigger	0	1=ON / 0=OFF	0	1	1
10053	Air Proving Switch	0	1=ON / 0=OFF	0	1	1

## 5 ModBus Memory Map for Regent

Input Registers						
Address	Description	Default	Unit	Min.	Max.	Resolution
30001	Discrete Inputs 1 - 16	0	NA	0	65535	1
30002	Discrete Inputs 17 - 32	0	NA	0	65535	1
30003	Discrete Inputs 33 - 48	0	NA	0	65535	1
30004	System / Cascade Setpoint	0	°C	0	130	0.5
30006	Cascade Total Power	0	%	100	800	1
30007	Cascade Current Power	0	%	0	800	1
30008	Outlet Setpoint	0	°C	0	130	0.5
30009	Outlet Temperature	0	°C	0	130	0.1
30010	Inlet Temperature	0	°C	-20	130	0.1
30011	Flue Temperature	0	°C	-20	130	0.1
30012	Firing Rate	0	%	0	100	1
30014	Unit Status Code	0	NA	0	65535	1
30015	Unit Blocking Code	0	NA	0	65535	1
30016	Unit Lockout Code	0	NA	0	65535	1
30019	Air Damper Target Angle	0	NA	0	65535	1
30020	Gas Damper Target Angle	0	NA	0	65535	1
30021	Fan Speed Target	0	NA	0	65535	1
30023	O2 Sensor Status	0	NA	0	65535	1
30024	Current Trim Factor	0	NA	0	65535	1
30025	Barometer	0	NA	0	65535	1
30026	Discrete Inputs 49 - 64	0	NA	0	65535	1
30027	Lock-out Error Leader	0	NA	0	65535	1
30028	Lock-out Error Member 1	0	NA	0	65535	1
30029	Lock-out Error Member 2	0	NA	0	65535	1
30030	Lock-out Error Member 3	0	NA	0	65535	1
30031	Lock-out Error Member 4	0	NA	0	65535	1
30032	Lock-out Error Member 5	0	NA	0	65535	1
30033	Lock-out Error Member 6	0	NA	0	65535	1
30034	Lock-out Error Member 7	0	NA	0	65535	1
30036	Flame 1	0	NA	0	65535	1
30037	Flame 2	0	NA	0	65535	1
30038	Corrected O2 Reading	0	NA	0	65535	1
30039	Flow Rate	0	GPM	0	65535	1
Holding Registers						
Address	Description	Default	Unit	Min.	Max.	Resolution
40001	Configuration	0	NA	0	65535	1
40002	Coils	0	NA	0	65535	1
40003	0-10 Volt Input / Set Point Command	0	NA	0	65535	1
40004	DHW Setpoint	0	°C	0	87.5	0.5
40007	System Supply Temperature	0	°C	-20	130	0.1
40008	Building Recirculation Temperature	0	°C	-20	130	0.1

## 5 ModBus Memory Map for Regent

### Configuration Bits

Address 40001 contains configuration bits sent from the BAS to the boiler. These bits tell the boiler to use its own internal inputs, or inputs from the BAS. When a bit is set to 1, the boiler will ignore the corresponding value contained internally, and expect the BAS to write that value into the Holding Registers. The configuration bits are as follows:

- Bit 0 (LSB): Not Used
- Bit 1: DHW Thermostat
- Bit 2: 0 - 10V Input / Setpoint Command
- Bit 3: DHW Setpoint
- Bit 4: System Supply Temperature
- Bit 5: Not Used
- Bit 6: Not Used
- Bit 7: Building Recirculation Temperature
- Bit 8 - 15: Not Used (Default = 0)

## 6 BACnet Configuration

The BACnet communication board is equipped with a set of ten dip switches that are used to set the board configuration (address and baud rate). The first seven are used to set the address of each board. The eighth switch is used to select C(off) or F(on). The ninth and tenth are baud rate.

Figure 6-1\_Communication Board

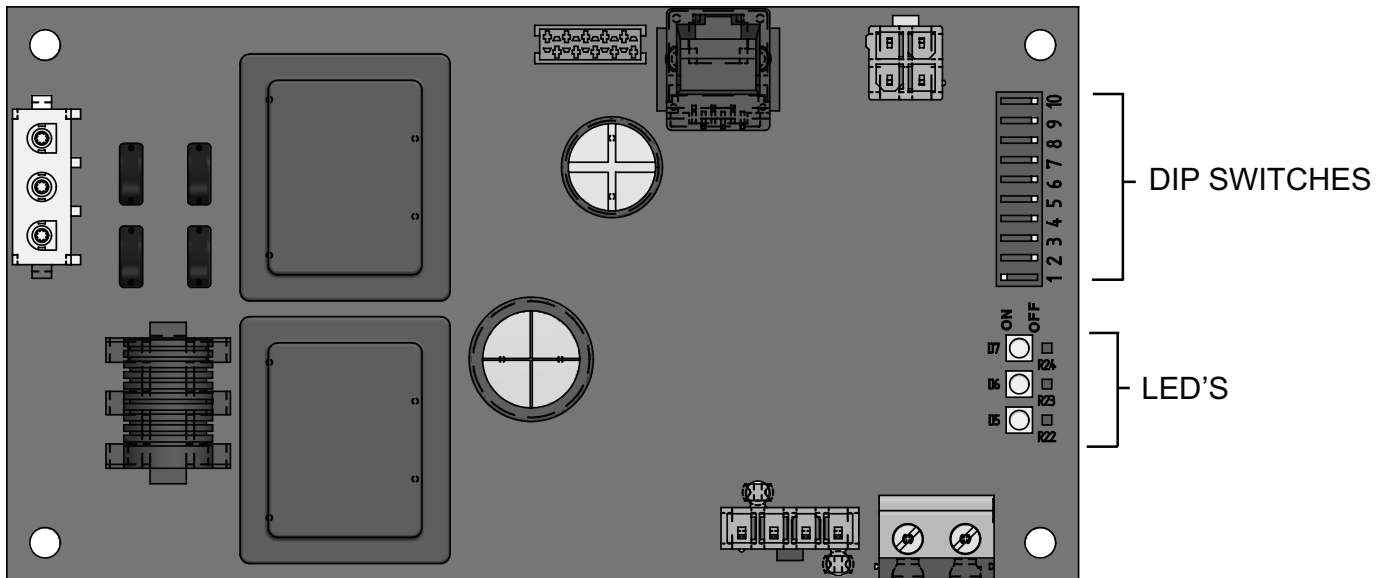

### Addressing

The BACnet local addressing space is comprised of 256 different addresses.

- Maximum address of 127.

Since the BACnet communication board is a BACnet master, address 127 is the highest address that can be used.

To set the BACnet local address, the dip switches can be set in either the 0 position or the 1 position. For switches set to the 1 position their value will be added together to determine the address.

For each switch set to the 1 position it has the following value:

- Dip switch 1 = 1
- Dip switch 2 = 2
- Dip switch 3 = 4
- Dip switch 4 = 8
- Dip switch 5 = 16
- Dip switch 6 = 32
- Dip switch 7 = 64

Any dip switch set to 0 has a value equal to 0.

*Example:*

To set the address of the BACnet board to 50, dip switches 2, 5, and 6 have to be set to the 1 position. The address is determined by adding the values of all the dip switches together.

Address = Value of Dip switch 1 + Value of Dip switch 2 + Value of Dip switch 3 + Value of Dip switch 4 + Value of Dip switch 5 + Value of Dip switch 6 + Value of Dip switch 7

In this example:

$$\text{Address} = 0 + 2 + 0 + 0 + 16 + 32 + 0 = 50$$

The BACnet Device Instance is calculated by adding the BACnet local addresses. The addresses are:

- 610000 = FB 751-2001
- 670000 = FB 2501-6001
- 680000 = FCB1000-6000 and IWH500-1000

Using the above example, the Device Instance will be:

$$\text{Device Instance} = 610000 + 50 = 610050$$

The base address (610000 in this example) is model dependant and can be changed by the integrator. It can be set to any value between 0 and 4194048. The resulting device instance will be this value + the local address, as before. Once the base address is changed, it can be reset back to the default base address (610000 in this example) using the following procedure:

1. Turn OFF power to the interface board.
2. Set Dip switches 1 - 8 to the 1 position.
3. Turn ON power to the interface board.
4. After a few seconds, turn OFF power to the interface board.
5. Set Dip switches 1 - 7 to the desired local address.
6. Turn ON power to the interface board.

## 6 BACnet Configuration

### °F/°C Setting

Accomplish the different selections with Dip switch #8 on the board. The OFF position displays Celsius while the ON position is Fahrenheit.

### Device Name

The default device name is “MTR-01 BACnet.” This can be changed by the integrator as desired.

### Timing Specifications

The baud rate for the BACnet board is selectable with Dip switches #9 and #10.

Switch #9	Switch#10	Baud Rate
OFF	OFF	9600
ON	OFF	19200
OFF	ON	38400
ON	ON	76800

When the system supply temperature and/or tank temperature is provided by the BAS to the unit, it is critical that the temperature be updated every few seconds. If the unit does not receive updated temperatures within a timeout period, then the control will revert to using its own sensor inputs (if sensors are connected). For Crest models, the timeout is programmable by pressing the MAIN MENU >>SETUP>>BAS buttons. The timeout is adjustable between 5 and 120 seconds.

For Hellcat and Regent, the timeout is not programmable. The default timeout is 300 seconds.

For Crest, when the BAS is not providing either of these temperatures but still controlling the boiler (such as providing a modulation command), the BAS must refresh these commands at least every 4 minutes. If the commands are not refreshed, the boiler will revert to operating based on its own inputs.

For Regent, when the BAS is providing a set point command, the BAS must refresh this command at least every 4 seconds. If the command is not refreshed, the unit will revert to operating based on its own inputs.

### Communication Board Diagnostics

The Communication board is equipped with three LED's for visual diagnostics: Two yellow LED's and one green. One yellow LED (D5) is used to indicate transmission of data. The other yellow LED (D6) is used to indicate reception of data. The green LED (D7) is used to show internal faults.

#### Internal Faults:

Normal Operation = 1 second bright, 1 second dim

Controller Fault = Continuously on

No Burner Control Communication = 0.5 seconds on, 1.5 seconds off

No BACnet Communication = 1.5 seconds on, 0.5 seconds off.

# 7 BACnet Memory Map for Crest and Hellcat

## Primary Data Tables

Object Type	Data Type	Read / Write
Binary Input (BI)	Single Bit	Read Only
Binary Value (BV)	Single Bit	Read / Write
Analog Input (AI)	16-Bit Word	Read Only
Analog Value (AV)	16 Bit Word	Read / Write

## Memory Map

Object Name	Object Type	Object Instance	Units	Min	Max	Resolution
<b>Binary Values</b>						
Boiler Enable	BV	0	none	0	1	1
Tank Thermostat	BV	4	none	0	1	1
<b>Binary Inputs</b>						
Manual Reset High Limit	BI	0	none	0	1	1
Flow Switch	BI	1	none	0	1	1
Gas Pressure Switch	BI	2	none	0	1	1
Louver Proving Switch	BI	3	none	0	1	1
Proof of Closure*** (can be used for FB/OF4001-6001)	BI	4	none	0	1	1
Blocked Drain Switch	BI	5	none	0	1	1
Flame 1	BI	7	none	0	1	1
Enable <sup>†</sup>	BI	8	none	0	1	1
Tank Thermostat <sup>†</sup>	BI	9	none	0	1	1
Blocked Vent Switch	BI	10	none	0	1	1
Fan 2 Proving Switch <sup>†</sup> (Older, dual fan models only)	BI	12	none	0	1	1
Internal LWCO ***	BI	17	none	0	1	1
Gas Pressure Switch 2 ***	BI	18	none	0	1	1
Flue Damper Switch	BI	20	none	0	1	1
Flame 2	BI	22	none	0	1	1
Enable***	BI	25	none	0	1	1
Tank Thermostat***	BI	29	none	0	1	1
Run Time Contacts	BI	32	none	0	1	1
Alarm Contacts	BI	33	none	0	1	1
Boiler Pump	BI	34	none	0	1	1
DHW Pump	BI	35	none	0	1	1
Louver Relay	BI	36	none	0	1	1
Gas Valve 1	BI	37	none	0	1	1
System Pump	BI	38	none	0	1	1
DHW Recirc Pump ***	BI	40	none	0	1	1
Flue Damper Output	BI	43	none	0	1	1
Gas Valve 2	BI	45	none	0	1	1

<sup>†</sup> Crest Models 751 - 6001 Only

\* Crest Models 4001 - 6001 Only

\*\* Crest Models 751- 3501 Only

\*\*\*Crest Models FCB1000-6001 Only

# 7 BACnet Memory Map for Crest and Hellcat

## Memory Map *(continued)*

Object Name	Object Type	Object Instance	Units	Min	Max	Resolution
<b>Binary Inputs</b>						
Transition Gas Valve**	BI	46	none	0	1	1
Main Fan 1	BI	48	none	0	1	1
Main Fan 2* (Dual fan models only)	BI	49	none	0	1	1
External Spark / HSI	BI	50	none	0	1	1
Air Valve Trigger	BI	51	none	0	1	1
Air Valve Proving	BI	52	none	0	1	1
<b>Inputs</b>						
Binary Inputs 0-15	AI	0	none	0	65535	1
Binary Inputs 16-31	AI	1	none	0	65535	1
Binary Inputs 32-47	AI	2	none	0	65535	1
System / Cascade Setpoint	AI	3	°C	0	130	0.5
System Pump Speed	AI	4	%	0	100	1
Cascade Total Power	AI	5	%	100	800	1
Cascade Current Power	AI	6	%	0	800	1
Outlet Setpoint	AI	7	°C	0	130	0.5
Outlet Temperature	AI	8	°C	0	130	0.1
Inlet Temperature	AI	9	°C	-20	130	0.1
Flue Temperature	AI	10	°C	-20	130	0.1
Firing Rate	AI	11	%	0	100	1
Boiler Pump Speed	AI	12	%	0	100	1
Boiler Status Code	AI	13	none	0	65535	1
Boiler Blocking Code	AI	14	none	0	65535	1
Boiler Lockout Code	AI	15	none	0	65535	1
Air Damper Target Angle***	AI	18	none	0	65535	1
Gas Damper Target Angle***	AI	19	none	0	65535	1
Fan Speed Target***	AI	20	none	0	65535	1
O2 Sensor Status ***	AI	22	none	0	65535	1
Current Trim Factor ***	AI	23	none	0	65535	1
Barometer ***	AI	24	none	0	65535	1
Binary Inputs 48-63	AI	25	none	0	65535	1
Lock-Out Error Leader	AI	26	none	0	1	1
Lock-Out Error Member 1	AI	27	none	0	1	1
Lock-Out Error Member 2	AI	28	none	0	1	1
Lock-Out Error Member 3	AI	29	none	0	1	1
Lock-Out Error Member 4	AI	30	none	0	1	1
Lock-Out Error Member 5	AI	31	none	0	1	1
Lock-Out Error Member 6	AI	32	none	0	1	1
Lock-Out Error Member 7	AI	33	none	0	1	1
Flame 1 ***	AI	35	none	0	65535	1
Flame 2 ***	AI	36	none	0	65535	1
Corrected O2 Reading ***	AI	37	none	0	65535	1

† Crest Models 751 - 6001 Only  
 \*\* Crest Models 751- 1501 Only

\* Crest Models 2501 - 6001 Only  
 \*\*\*Crest Models FCB1000-6001 Only

# 7 BACnet Memory Map for Crest and Hellcat

## Memory Map *(continued)*

Object Name	Object Type	Object Instance	Units	Min	Max	Resolution
<b>Analog Values</b>						
Configuration	AV	0	none	0	65535	1
Coils	AV	1	none	0	65535	1
0-10 Volt Input / Rate Command / Setpoint Command	AV	2	%	0	100	1
Tank Setpoint	AV	3	°C	0	87,5	0.5
Tank Temperature	AV	4	°C	-20	130	0.1
Outdoor Temperature	AV	5	°C	-40	60	0.1
System Supply Temperature	AV	6	°C	-20	130	0.1
System Return Temperature	AV	7	°C	-20	130	0.1

† Crest Models 751 - 6001 Only

\* Crest Models 2501 - 6001 Only

\*\* Crest Models 751- 1501 Only

\*\*\*Crest Models FCB1000-6001 Only

## 8 BACnet Memory Map for Regent

### Primary Data Tables

Object Type	Data Type	Read / Write
Binary Input (BI)	Single Bit	Read Only
Binary Value (BV)	Single Bit	Read / Write
Analog Input (AI)	16-Bit Word	Read Only
Analog Value (AV)	16 Bit Word	Read / Write

### Memory Map

Object Name	Object Type	Object Instance	Units	Min	Max	Resolution
<b>Binary Values</b>						
DHW Thermostat	BV	4	none	0	1	1
<b>Binary Inputs</b>						
Hex Door Temperature Switch / MRHL	BI	0	none	0	1	1
Flow Switch	BI	1	none	0	1	1
Gas Pressure Switch 1	BI	2	none	0	1	1
Proof of Closure	BI	4	none	0	1	1
Blocked Drain Switch	BI	5	none	0	1	1
Flame 1	BI	7	none	0	1	1
Blocked Vent Switch	BI	10	none	0	1	1
Gas Pressure Switch 2	BI	18	none	0	1	1
Flue Damper Switch	BI	20	none	0	1	1
Flame 2	BI	22	none	0	1	1
DHW Thermostat	BI	29	none	0	1	1
Run Time Contacts	BI	32	none	0	1	1
Alarm Contacts	BI	33	none	0	1	1
Internal Circulation Pump	BI	34	none	0	1	1
Cascade Isolation Valve	BI	35	none	0	1	1
Gas Valve	BI	37	none	0	1	1
Building Recirculation Pump	BI	40	none	0	1	1
Flue Damper Output	BI	43	none	0	1	1
Main Fan	BI	48	none	0	1	1
External Spark / HSI	BI	50	none	0	1	1
Air Valve Trigger	BI	51	none	0	1	1
Air Proving Switch	BI	52	none	0	1	1

## 8 BACnet Memory Map for Regent

### Memory Map *(continued)*

Object Name	Object Type	Object Instance	Units	Min	Max	Resolution
<b>Analog Inputs</b>						
Binary Inputs 0-15	AI	0	none	0	65535	1
Binary Inputs 16-31	AI	1	none	0	65535	1
Binary Inputs 32-47	AI	2	none	0	65535	1
System / Cascade Setpoint	AI	3	°C	0	130	0.5
System Pump Speed	AI	4	5	0	100	1
Cascade Total Power	AI	5	5	100	800	1
Cascade Current Power	AI	6	5	0	800	1
Outlet Setpoint	AI	7	°C	0	130	0.5
Outlet Temperature	AI	8	°C	0	130	0.1
Inlet Temperature	AI	9	°C	-20	130	0.1
Flue Temperature	AI	10	°C	-20	130	0.1
Firing Rate	AI	11	%	0	100	1
Unit Status Code	AI	13	none	0	65535	1
Unit Blocking Code	AI	14	none	0	65535	1
Unit Lockout Code	AI	15	none	0	65535	1
Air Damper Target Angle	AI	18	none	0	65535	1
Gas Damper Target Angle	AI	19	none	0	65535	1
Fan Speed Target	AI	20	none	0	65535	1
O2 Sensor Status	AI	22	none	0	65535	1
Current Trim Factor	AI	23	none	0	65535	1
Barometer	AI	24	none	0	65535	1
Binary Inputs 48-63	AI	25	none	0	65535	1
Lock-Out Error Leader	AI	26	none	0	1	1
Lock-Out Error Member 1	AI	27	none	0	1	1
Lock-Out Error Member 2	AI	28	none	0	1	1
Lock-Out Error Member 3	AI	29	none	0	1	1
Lock-Out Error Member 4	AI	30	none	0	1	1
Lock-Out Error Member 5	AI	31	none	0	1	1
Lock-Out Error Member 6	AI	32	none	0	1	1
Lock-Out Error Member 7	AI	33	none	0	1	1
Flame 1	AI	35	none	0	65535	1
Flame 2	AI	36	none	0	65535	1
Corrected O2 Reading	AI	37	none	0	65535	1
Flow Rate	AI	38	none	0	65535	1

## 8 BACnet Memory Map for Regent

### Memory Map *(continued)*

Object Name	Object Type	Object Instance	Units	Min	Max	Resolution
<b>Analog Values</b>						
Configuration	AV	0	none	0	65535	1
Coils	AV	1	none	0	65535	1
0-10 Volt Input / Setpoint Command	AV	2	%	0	100	1
DHW Setpoint	AV	3	°C	0	87.5	0.5
System Supply Temperature	AV	6	°C	-20	130	0.1
Building Recirculation Temperature	AV	7	°C	-20	130	0.1

# 9 Wiring Requirements

When the system supply temperature and/or tank temperature is provided by the BAS to the unit, it is critical that the temperature be updated every few seconds. If the unit does not receive updated temperatures within a timeout period, then the control will revert to using its own sensor inputs (if sensors are connected). For Crest models, the timeout is programmable by pressing the MAIN MENU >>SETUP>>BAS buttons. The timeout is adjustable between 5 and 120 seconds.

For Hellcat and Regent, the time timeout is not programmable. The default timeout is 300 seconds.

## Physical Wiring

### RS-485 Communication Bus

- Maximum Length = 4000 feet
- Cable Specification = 24 AWG / A,B (twisted pair) and GND Shielded, with characteristic Impedance = 120 ohm
- Maximum Load = 32 units (32 nodes)

**NOTE:** Cable must be terminated with 120 ohm impedance matching resistor on each end.

- A + (positive)
- B - (negative)

**Figure 9-1A** Crest - Low Voltage Terminal Strip Connections

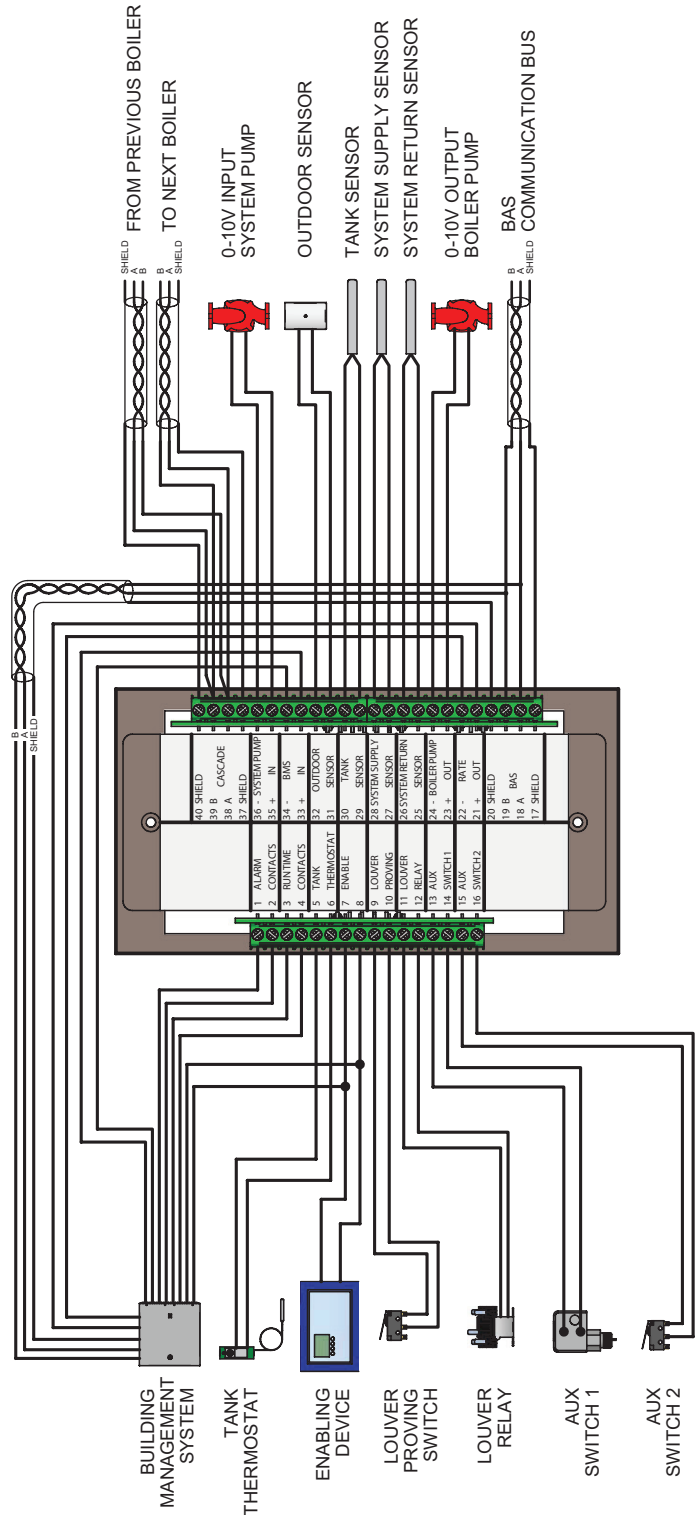

# 9 Wiring Requirements

Figure 9-1B Hellcat- Low Voltage Terminal Strip Connections

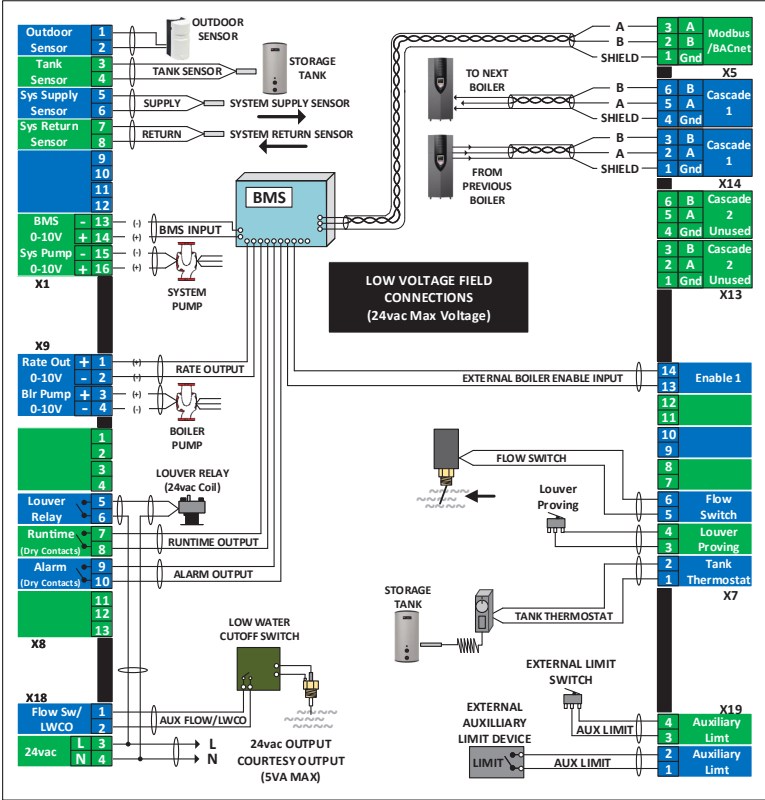
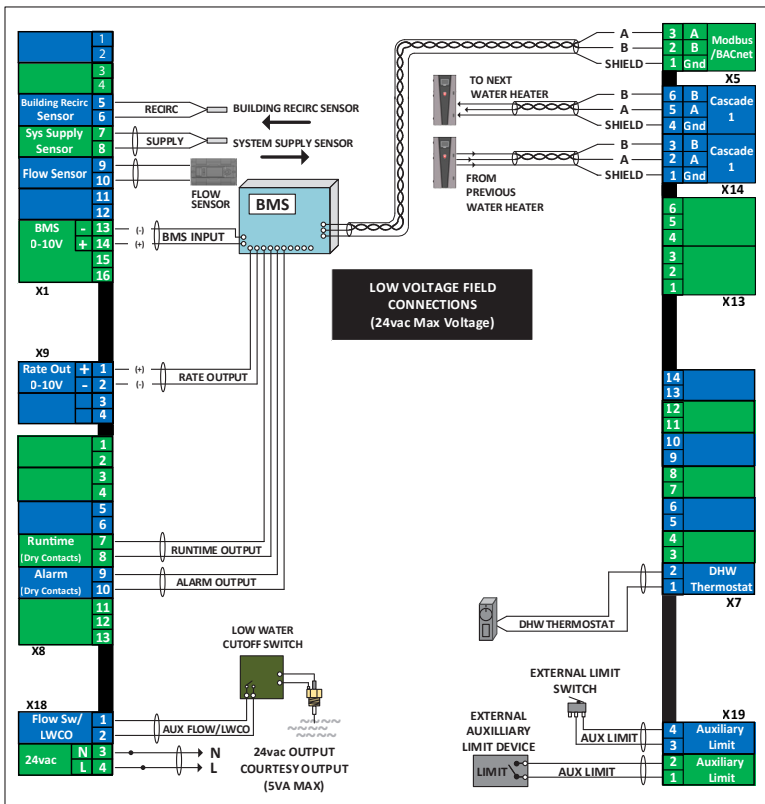
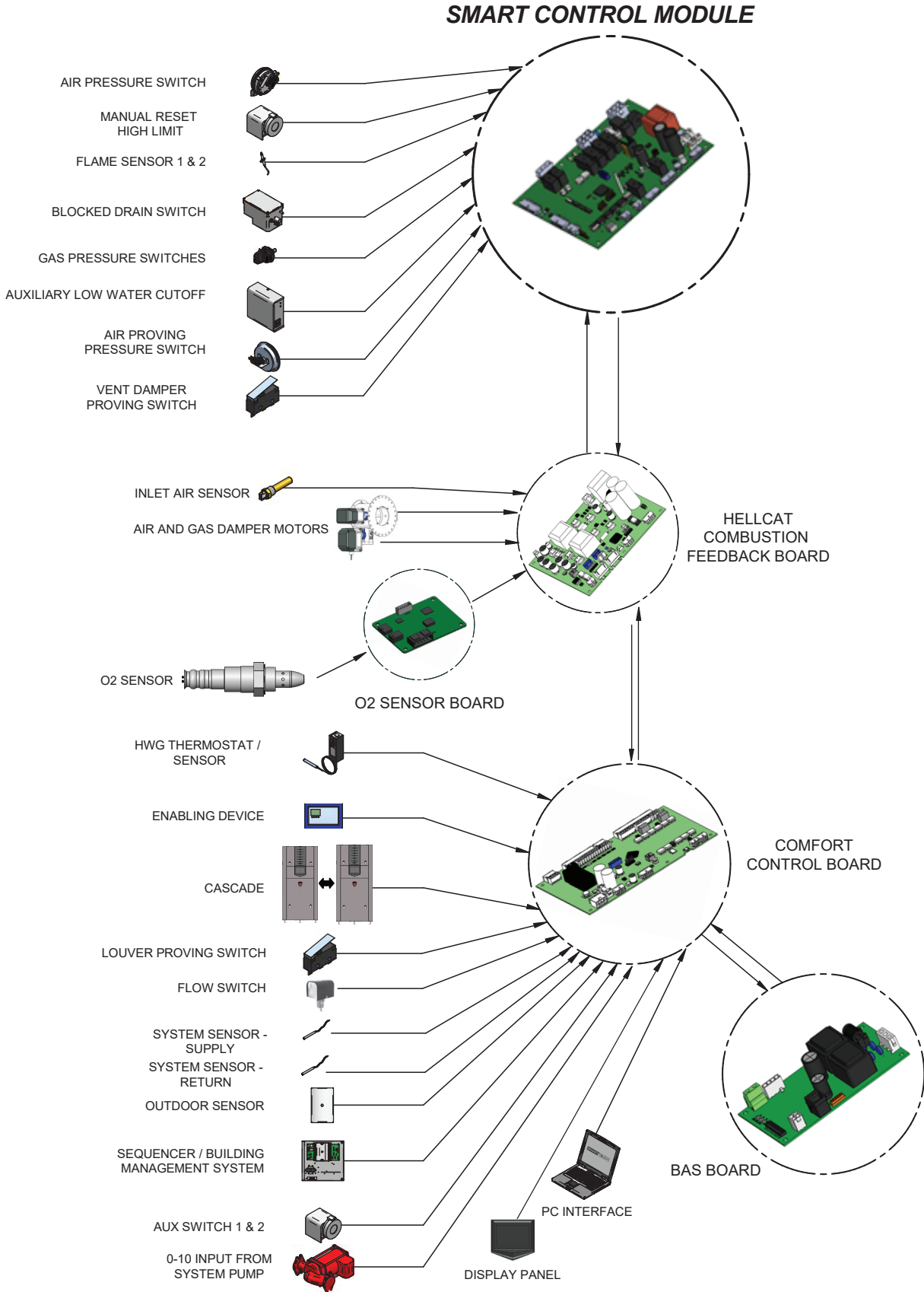

Figure 9-1C Regent - Low Voltage Terminal Strip Connections



# 9 Wiring Requirements

Figure 9-2A Hellcat - Control Inputs



# 9 Wiring Requirements

Figure 9-2B Crest - Control Inputs

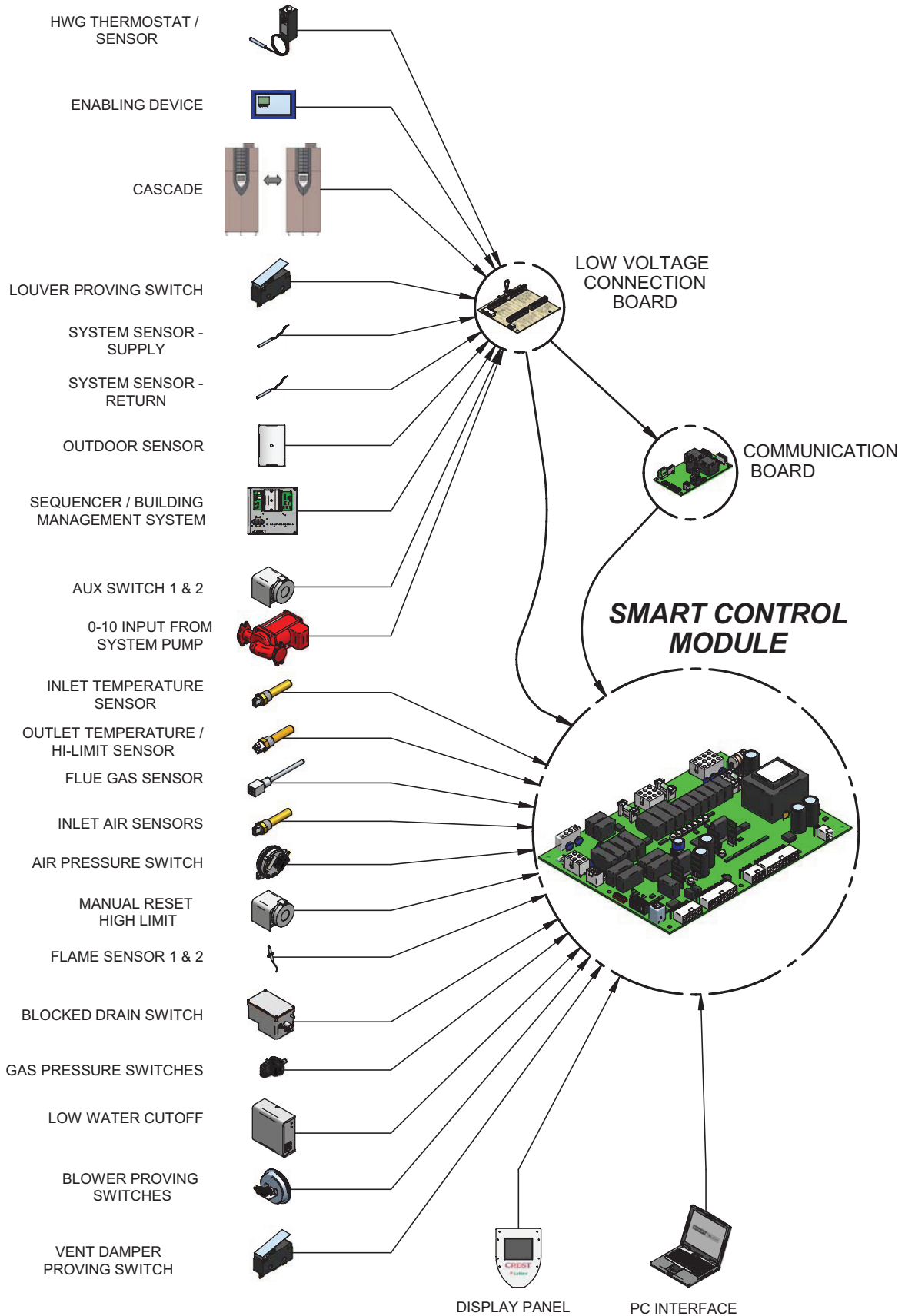

# 9 Wiring Requirements *(continued)*

Figure 9-2C Regent - Control Inputs

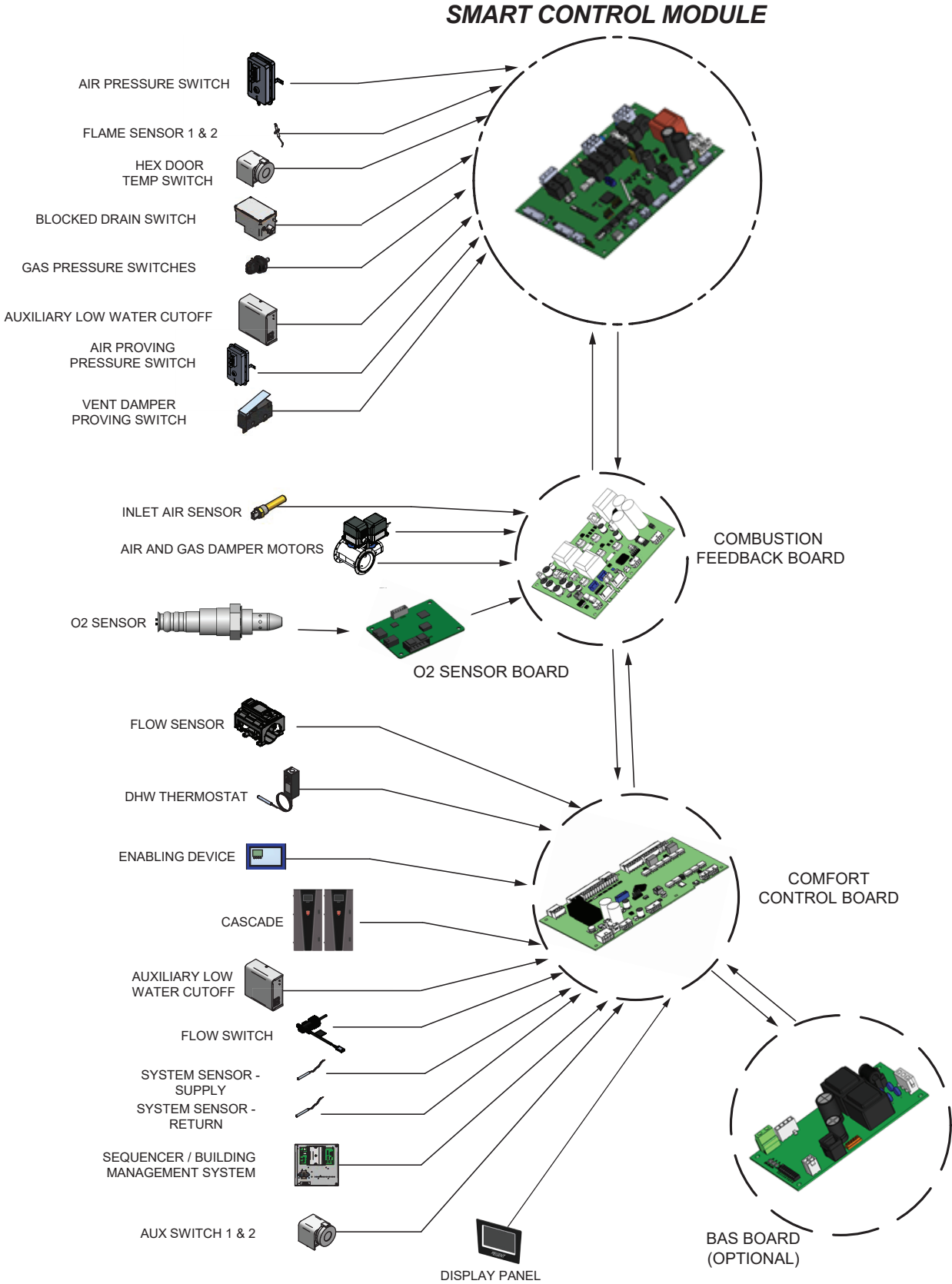

# 9 Wiring Requirements *(continued)*

Figure 9-3A Hellcat - Control Outputs

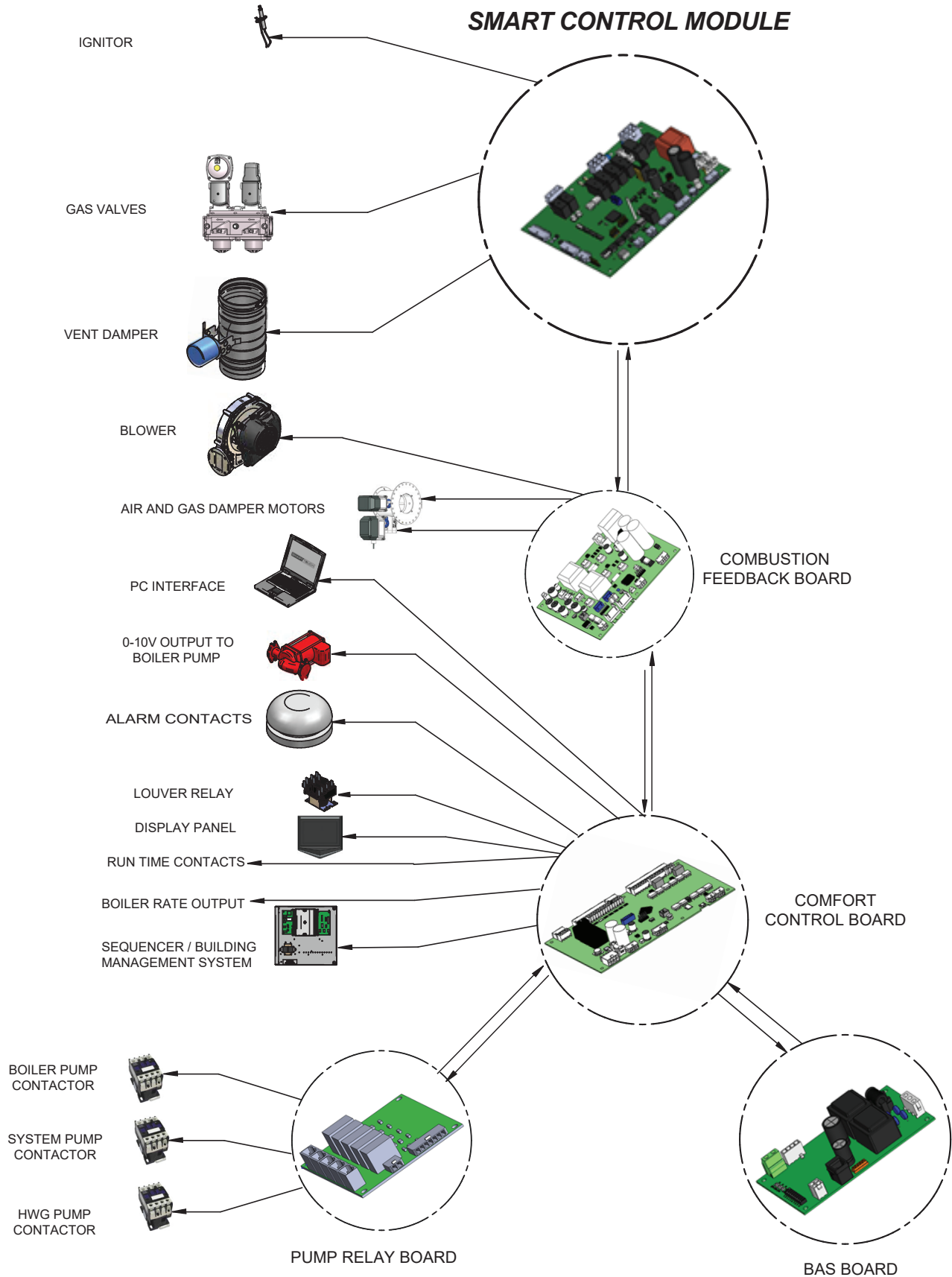

# 9 Wiring Requirements *(continued)*

Figure 9-3B Crest - Control Outputs

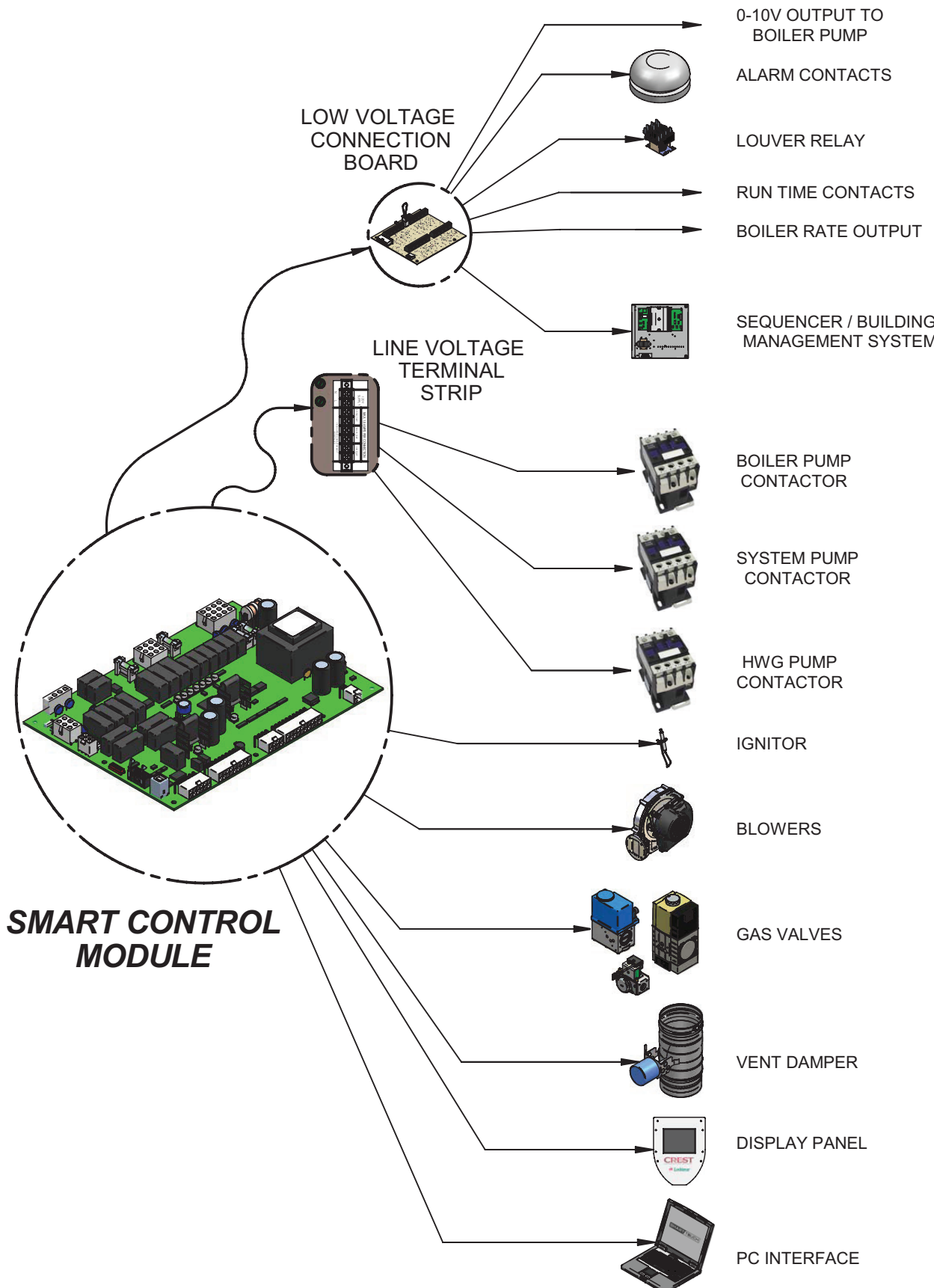

# 9 Wiring Requirements *(continued)*

Figure 9-3C Regent - Control Outputs

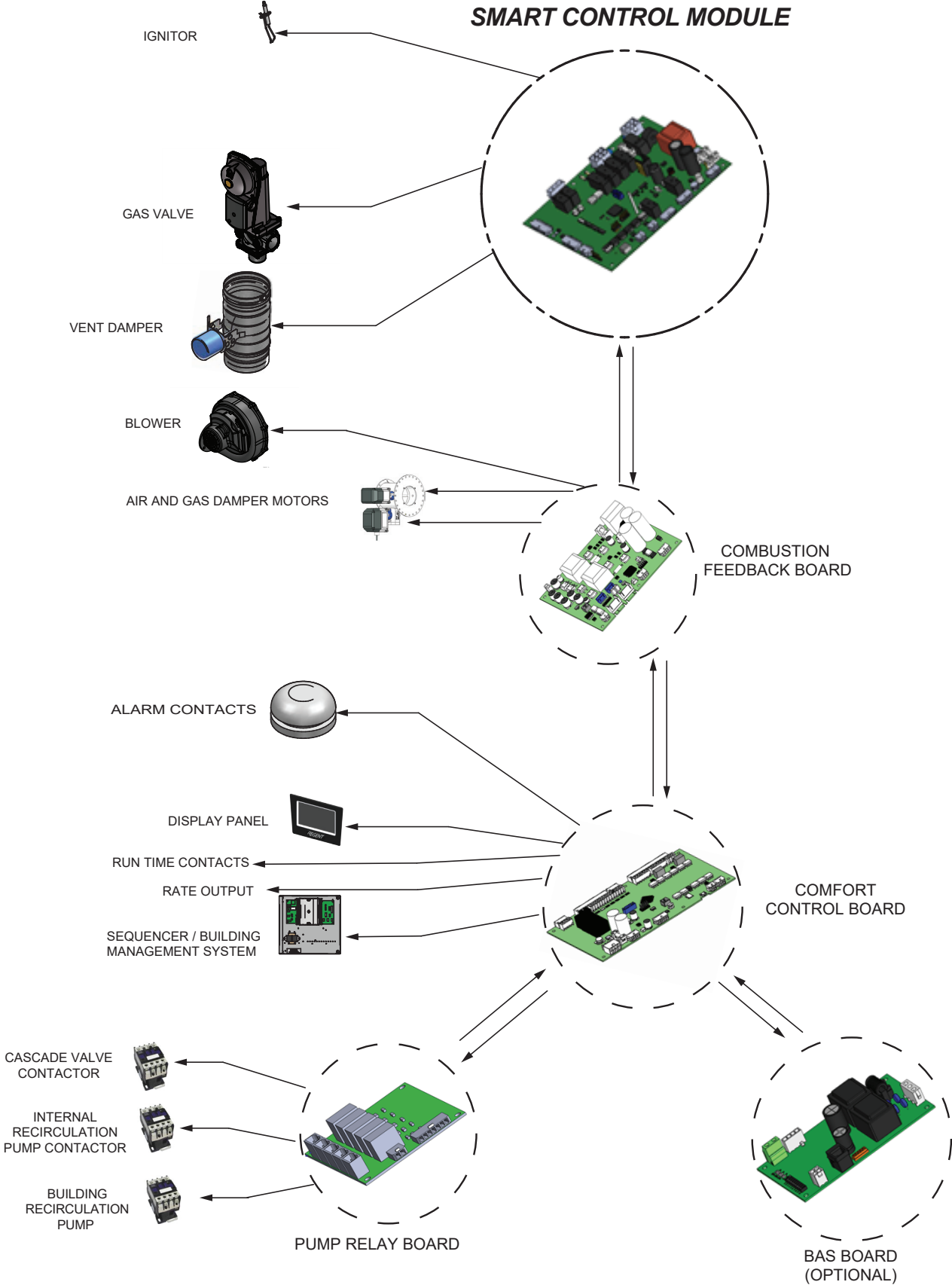

# 9 Wiring Requirements

Figure 9-4A Crest - Control Location

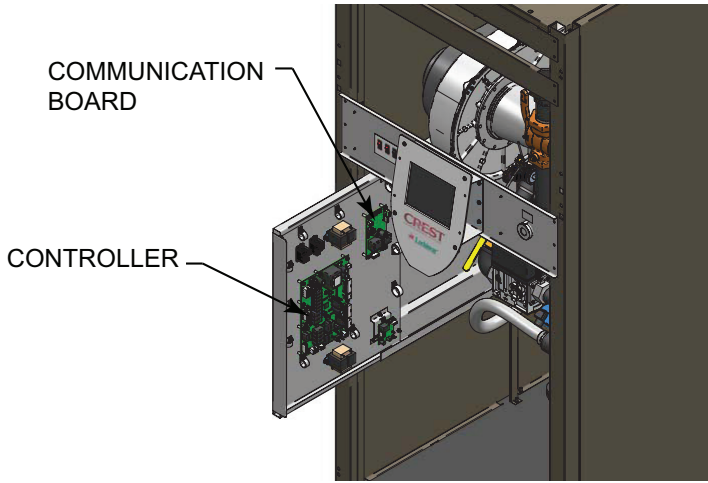

Figure 9-4C Regent - Control Location

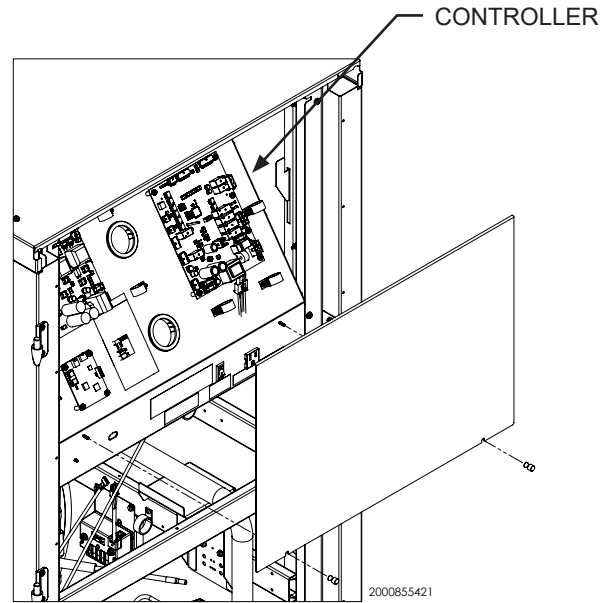
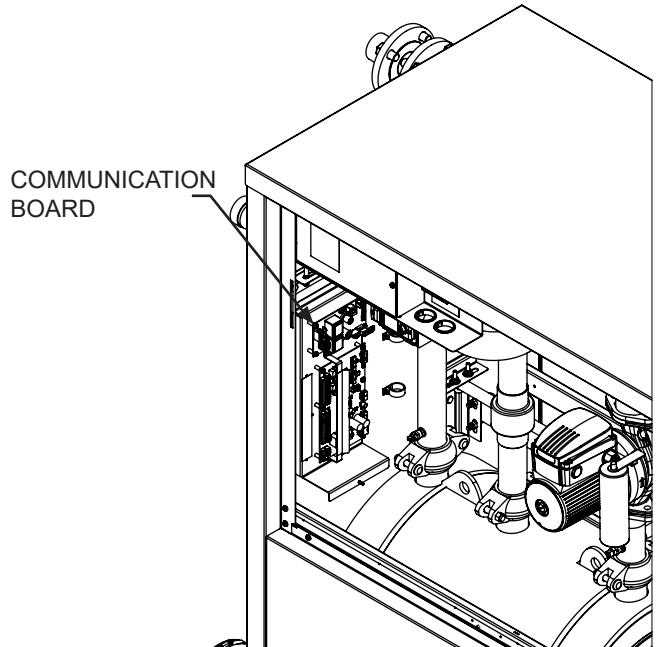
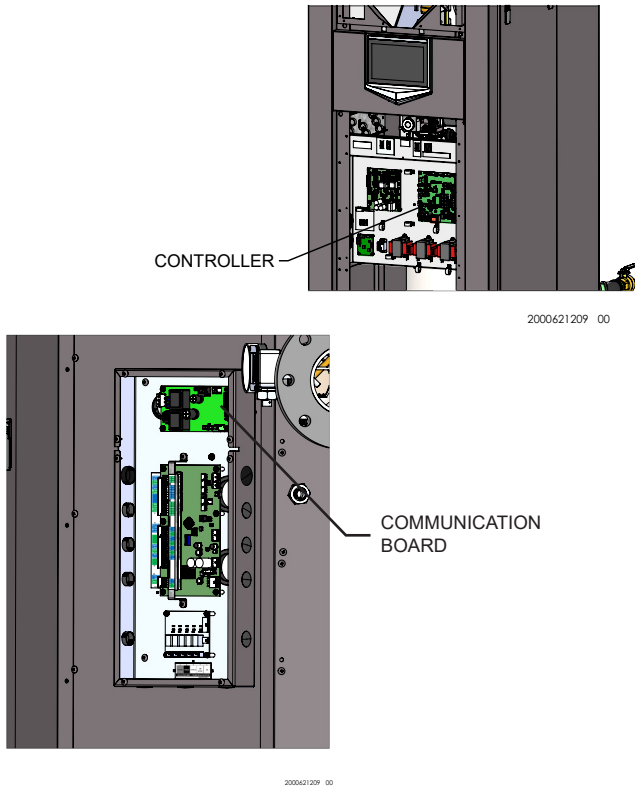

Figure 9-4B Hellcat - Control Location



# 9 Wiring Requirements

## Typical Cascade System Wiring

**Physical Configuration: Cascade without Individual Monitoring**

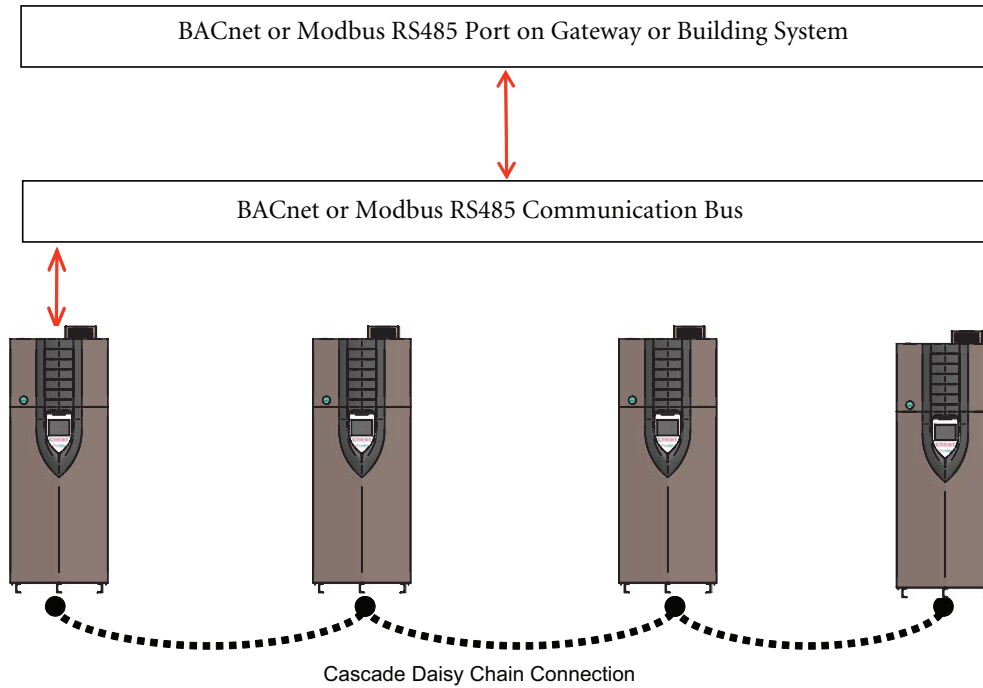

**Physical Configuration: Cascade with individual Monitoring**

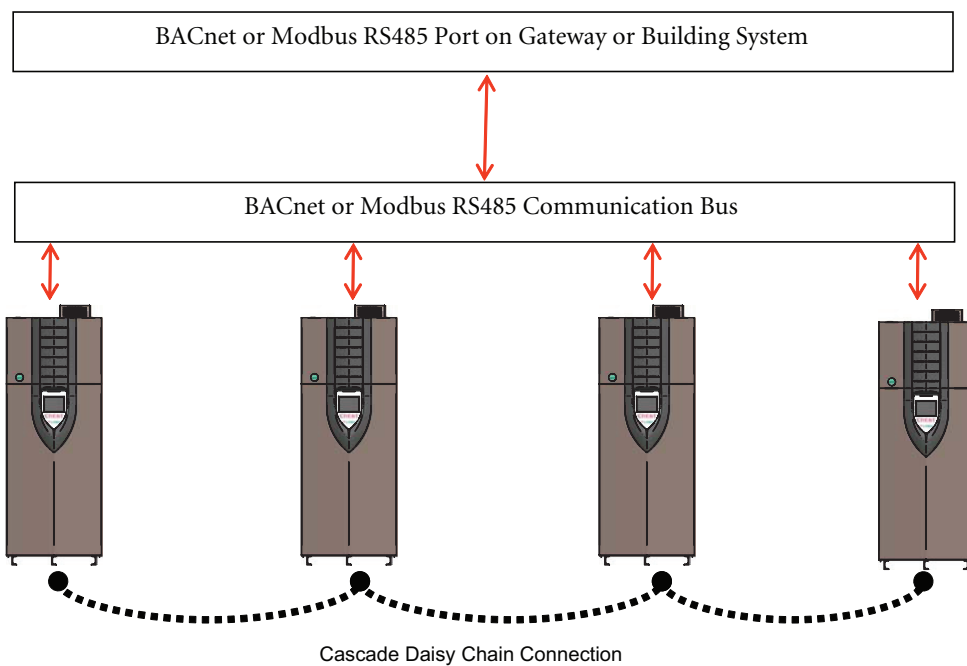

## 9 Wiring Requirements *(continued)*

### Physical Configuration: Direct Control

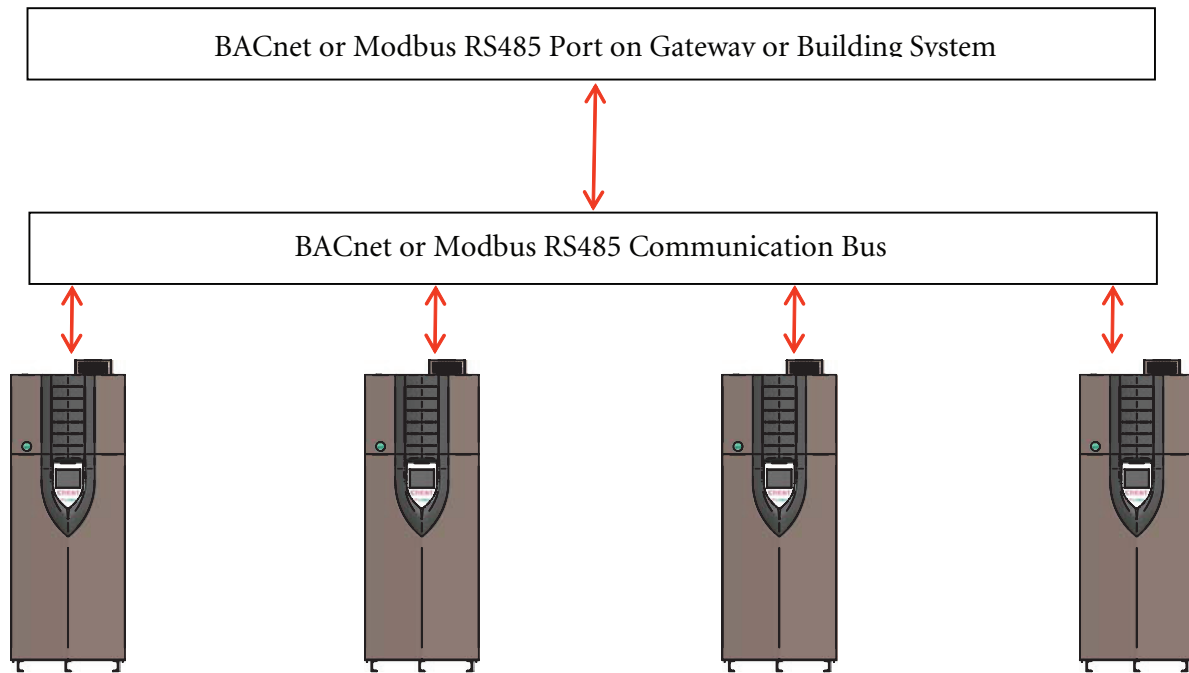

# 10 Unit Operation for Crest and Hellcat

## Unit Operation with ModBus / BACnet Communications

To control a Crest boiler through a Building Management System communicating through ModBus or BACnet, the Crest Demand Configuration must be set to one of three options. These configurations allow different control points for a variety of applications. The configuration can be set by selecting Main Menu>>Setup>>BMS.

The Crest boiler is equipped with a ModBus communication timer. This timer is programmable on Crest models only from 5 - 120 seconds. The timer can be programmed from the ModBus Setup Menu by selecting Main Menu>>Setup>>BAS. The purpose of the timer is to ensure proper temperature data is communicated to the boiler in a timely manner. Additionally, it will provide for fail safe operation should ModBus communication be lost. This timer will cause the unit to revert back to internal unit controls should the ModBus communication be interrupted longer than the ModBus timer. The timer is reset every time a ModBus write command is received with updated temperatures or commands. It is the recommendation of Lochinvar that this timer be set to the shortest value possible.

When controlling a Crest boiler through a Building Automation System (BAS), it is very important to ensure that the correct configuration bits are sent to holding register 40001 or Object AV0, and that the correct data and enable signals are sent to holding registers 40002 - 40007 or Objects AV1 - AV6, per the demand configuration.

### Demand Configuration: ENABLE = ACTIVE; BMS = INACTIVE

In this configuration the unit is controlled by setting the setpoints locally on the boiler and providing an enable signal through ModBus or BACnet communications.

All sensors and limiting devices should be hardwired to the terminal strip on the back of the unit excluding the enable signal. This signal will be sent to the unit via ModBus.

The holding registers will need to be set as follows:

Object	Holding Registers	Definition	Bit Value (HEX)	Action
AV0	40001	Configuration	00 01	Set Configuration to read 40002
AV1	40002	Coils	00 01	Enables unit ( <i>00 00 disables unit</i> )

**NOTE:** To ensure proper operation re-send the configuration bits to holding register 40001 or Object AV0 prior to issuing a command.

# 10 Unit Operation for Crest and Hellcat<sub>(continued)</sub>

## Demand Configuration: ENABLE = ACTIVE; BMS = ACTIVE

In this configuration the unit is controlled by providing an enable signal. The setpoint command will be determined by the parameters in the control and a rate command through ModBus or BACnet communications.

The rate command will be 0 - 100% of modulation.

All sensors and limiting devices should be hardwired to the terminal strip on the back of the unit excluding the enable and 0-10V BMS signal. These signals will be sent to the unit via ModBus or BACnet.

The holding registers will need to be set as follows:

Object	Holding Registers	Definition	Bit Value (HEX)	Action
AV0	40001	Configuration	00 05	Set Configuration to read 40002 & 3
AV1	40002	Coils	00 10	Enables unit (00 00 disables unit)
AV2	40003	Rate Command	00 ##	Sets Modulation % or Setpoint

**NOTE:** To ensure proper operation re-send the configuration bits to holding register 40001 or Object AV0 prior to issuing a command.

For proper hexadecimal conversion of rate percentage, please refer to the Rate and Temperature Conversion section on page 41 of this manual.

## Demand Configuration: ENABLE = INACTIVE; BMS = ACTIVE

In this configuration the unit is controlled by setting the modulation setpoint from 0 - 100%, or the setpoint. The setpoint command will be determined by the parameters in the control.

Rate command will be 0 - 100% of the modulation range.

All sensors and limiting devices should be hardwired to the terminal strip on the back of the unit excluding the 0 - 10Vdc signal. This signal will be sent to the unit via ModBus or BACnet.

The holding registers will need to be set as follows:

Object	Holding Registers	Definition	Bit Value (HEX)	Action
AV0	40001	Configuration	00 04	Set Configuration to read 40003
AV2	40003	Rate Command	00 00	Sets Modulation % or Setpoint

**NOTE:** To ensure proper operation re-send the configuration bits to holding register 40001 or Object AV0 prior to issuing a command.

For proper hexadecimal conversion of rate percentage, please refer to the Rate and Temperature Conversion section on page 41 of this manual.

## Hot Water Generation

Hot water generation can be accomplished with one of two methods when a Crest boiler is connected to a BAS system, DHW with direct control, and DHW with remote control.

### DHW with direct control:

This is the typical installation with a hot water generator in close proximity to the boiler with the tank thermostat, or tank temperature sensor, wired to the terminal strip of the unit.

# 10 Unit Operation for Crest and Hellcat

## DHW with remote control:

This installation may or may not have the hot water generator in close proximity to the boiler. Its sensors and thermostat values are only available through the ModBus or BACnet communication bus.

To ensure that the Crest boiler can properly respond to a call for hot water generation the following holding registers must be set in addition to other commands:

Object	Holding Registers	Definition	Bit Value (HEX)	Action
AV0	40001	Configuration	00 4A	Set Configuration to read 40002, 4 & 5
AV1	40002	Coils	00 10	Enables Tank Tstat ( <i>00 00 disables unit</i> )
AV3	40004	Tank Setpoint	0# ##	Sets Setpoint
AV4	40005	Tank Temperature	0# ##	Passes tank temp from remote sensor

**NOTE:** To ensure proper operation re-send the configuration bits to holding register 40001 or Object AV0 prior to issuing a command.

For proper hexadecimal conversion of rate percentage, please refer to the Rate and Temperature Conversion section on page 41 of this manual.

## Cascade

In order to operate the Crest boiler in Cascade with ModBus / BACnet communications, configure the leader boiler per the demand configurations in this manual. Connect the remaining boilers in the cascade through the normal cascade communications wiring. Cascade control can then be accomplished automatically through the leader boiler.

Please note that with ModBus / BACnet communication connected to only the leader boiler, total Cascade information can be seen through the communications link. If you wish to see all the individual temperatures of each unit in the Cascade, each unit will have to have a communication board. However, each unit can be monitored without the need to control each one individually.

## Monitoring Only

All Crest boilers are equipped with the communication board and can be set up to operate with its own internal controls. If necessary, ModBus / BACnet can be configured as a monitoring device by polling the communication board for the read only variables.

# 11 Unit Operation for Regent

## Unit Operation with ModBus / BACnet Communications

To control a Regent water heater through a Building Management System communicating through ModBus or BACnet, the Demand Configuration must be set to one of three options. These configurations allow different control points for a variety of applications. The configuration can be set by selecting Main Menu>>Setup>>BMS.

The Regent water heater is equipped with a ModBus communication timer which is set to 300 seconds. The purpose of the timer is to ensure proper temperature data is communicated to the boiler in a timely manner. Additionally, it will provide for fail safe operation should ModBus communication be lost. This timer will cause the unit to revert back to internal unit controls should the ModBus communication be interrupted longer than the ModBus timer.

When controlling a Regent water heater through a Building Automation System (BAS), it is very important to ensure that the correct configuration bits are sent to holding register 40001 or Object AV0, and that the correct data and enable signals are sent to holding registers 40002 - 40008 or Objects AV1 - AV7, per the demand configuration.

### Demand Configuration: ENABLE = ACTIVE; BMS = INACTIVE

In this configuration the unit is controlled by setting the setpoints locally on the boiler and providing an enable signal through ModBus or BACnet communications.

All sensors and limiting devices should be hardwired to the terminal strip on the back of the unit excluding the enable signal. This signal will be sent to the unit via ModBus.

The holding registers will need to be set as follows:

Object	Holding Registers	Definition	Bit Value (HEX)	Action
AV0	40001	Configuration	00 02	Set Configuration to read 40002
AV1	40002	Coils	00 10	Enables unit ( <i>00 00 disables unit</i> )

**NOTE:** To ensure proper operation re-send the configuration bits to holding register 40001 or Object AV0 prior to issuing a command.

# 11 Unit Operation for Regent

## Demand Configuration: ENABLE = ACTIVE; BMS = ACTIVE

In this configuration the unit is controlled by providing an enable signal. The setpoint command will be determined by the parameters in the control and a 0-10V input command through ModBus or BACnet communications.

All sensors and limiting devices should be hardwired to the terminal strip on the back of the unit excluding the enable and 0-10V BMS signal. These signals will be sent to the unit via ModBus or BACnet.

The holding registers will need to be set as follows:

Object	Holding Registers	Definition	Bit Value (HEX)	Action
AV0	40001	Configuration	00 06	Set Configuration to read 40002 & 3
AV1	40002	Coils	00 10	Enables unit ( <i>00 00 disables unit</i> )
AV2	40003	Setpoint Command	00 ##	Defines Setpoint

**NOTE:** To ensure proper operation re-send the configuration bits to holding register 40001 or Object AV0 prior to issuing a command.

For proper hexadecimal conversion of rate percentage, please refer to the Rate and Temperature Conversion section on page 41 of this manual.

## Demand Configuration: ENABLE = INACTIVE; BMS = ACTIVE

In this configuration the setpoint command will be determined by the parameters in the control and a 0-10V input command through ModBus or BACnet communications.

All sensors and limiting devices should be hardwired to the terminal strip on the back of the unit excluding the 0 - 10Vdc signal. This signal will be sent to the unit via ModBus or BACnet.

The holding registers will need to be set as follows:

Object	Holding Registers	Definition	Bit Value (HEX)	Action
AV0	40001	Configuration	00 04	Set Configuration to read 40003
AV2	40003	Setpoint Command	00 ##	Defines Setpoint

**NOTE:** To ensure proper operation re-send the configuration bits to holding register 40001 or Object AV0 prior to issuing a command.

For proper hexadecimal conversion of rate percentage, please refer to the Rate and Temperature Conversion section on page 41 of this manual.

# 11 Unit Operation for Regent

## Demand Configuration: ENABLE = ACTIVE; Setpoint provided by BAS:

In this configuration, the unit is controlled by providing an enable signal. The setpoint will be determined by a setpoint command through ModBus or BACnet communications. All sensors and limiting devices should be hardwired to the terminal strip on the back of the unit excluding the enable signal. This signal will be sent to the unit via ModBus or BACnet.

The holding registers need to be set as follows:

Object	Holding Registers	Definition	Bit Value (HEX)	Action
AV0	40001	Configuration	00 0A	Set Configuration to read 40002, 4 & 5
AV1	40002	Coils	00 10	Enables DHW Tstat ( <i>00 00 disables unit</i> )
AV3	40004	DHW Setpoint	0# ##	Sets Setpoint

**NOTE:** To ensure proper operation re-send the configuration bits to holding register 40001 or Object AV0 prior to issuing a command.

For proper hexadecimal conversion of rate percentage, please refer to the Rate and Temperature Conversion section on page 41 of this manual.

### Cascade

In order to operate the Regent water heater in Cascade with ModBus / BACnet communications, configure the leader boiler per the demand configurations in this manual. Connect the remaining water heaters in the cascade through the normal cascade communications wiring. Cascade control can then be accomplished automatically through the leader water heater.

Please note that with ModBus / BACnet communication connected to only the leader water heater, total Cascade information can be seen through the communications link. If you wish to see all the individual temperatures of each unit in the Cascade, each unit will have to have a communication board. However, each unit can be monitored without the need to control each one individually.

### Monitoring Only

All Regent water heaters are equipped with the communication board and can be set up to operate with its own internal controls. If necessary, ModBus / BACnet can be configured as a monitoring device by polling the communication board for the read only variables.

# 12 Rate and Temperature

## Rate and Temperature Conversions:

Crest and Crest with Hellcat models can be set to either a specific rate or temperature setpoint. Regent models can only accept BMS temperature setpoint

### Rate

When issuing a rate command the rate can be communicated as percent modulation or a desired setpoint, depending on the setting of the BMS Type in the BMS Setup Menu.

The proper data format for the modulation percentage is the direct conversion to hexadecimal. This conversion can be accomplished through online number based converters or some scientific calculators.

*For Example:*

Rate %	HEX
0	00
20	14
45	2D
60	3C
80	50
95	5F
100	64

To send a desired setpoint, the hexadecimal value must be determined through linear interpolation of programmable parameters on the BMS Setup Menu:

- BMS temperature set-point at low analog input
- BMS temperature set-point at high analog input

These variables set the temperature values corresponding to the minimum and maximum voltage settings of the 0-10 volt signal. The defaults are as follows:

PARAMETER	DEFAULT VALUES		DEFAULT
	Deg C	Deg F	Voltages
BMS temperature setpoint at low analog input	21	69.8	2
BMS temperature setpoint at high analog input	82	179.6	10

*For Example:*

Send a setpoint of 110°F.

The formula to use for the interpolation is:

Rate Command =

$$\frac{(\text{Desired Setpoint} - \text{BMS Temp at Low Analog Input}) (\text{High Voltage} - \text{Low Voltage})}{\text{BMS Temp at High Analog Input} - \text{BMS Temp at Low Analog Input}} + \text{Low Voltage}$$

$$\frac{(110 - 69.8)(10 - 2)}{179.6 - 69.8} + 2 = 4.92 \text{ Volts}$$

From the default values:

- Desired Setpoint = 110
- BMS Temp at Low Analog Input = 68
- BMS Temp at High Analog = 158
- High Voltage = 10
- Low Voltage = 2

$$[(110 - 69.8)(10 - 2) / (179.6 - 69.8)] + 2 = 4.92 \text{ Volts}$$

$$(4.92 / 10) \times 100 = 49.2$$

$$49 = 31 \text{ Hexadecimal}$$

A value of [00][31] in hexadecimal would be written to Holding register 40003 to issue a command for a 110°F setpoint.

### Temperature

The Lochinvar boiler or water heater passes temperature data in degrees Celsius. Also, to accommodate decimal places the decimal value must be divided by 10.

Here are the conversions to and from Celsius:

$$T_c = (5/9) * (T_f - 32) \quad T_f = (9/5) * T_c + 32$$

*Example:*

Outdoor temperature from remote sensor on BAS System = 80°F

$$80^\circ\text{F} = 26.7^\circ\text{C}$$

Data that needs to be transmitted is  $26.7 * 10 = 267$

Decimal	Binary	HEX
267	100001011	10B

Outlet temperature from unit sensor = 155°F

$$155^\circ\text{F} = 68.3^\circ\text{C}$$

Data transmitted from unit in HEX = 2AB = 683

$$683 \div 10 = 68.3 (\text{°C})$$

Decimal	Binary	HEX
683	1010101011	2AB

# 13 Troubleshooting

Should you encounter problems communicating over ModBus, the following items should be checked in this order:

1. Physical Layer
2. Communications Configuration and Port Settings
3. ModBus Error Codes
4. Unit Status / Blocking / Lockout Codes

## Physical Layer

1. Check that all components have power (Boiler, Gateway, BAS Master)
2. Check all wire lengths. Are any drops too long?
3. Check proper shield grounding
4. Check A, B terminal connections
5. Check for Terminating Resistors (120 ohms)
6. Check for broken wires

## Communications

1. Check Dip Switch Configuration of MTR-01 Board
2. Check Baud Rate (9600, 19200)
3. Check Parity
4. Check Slave ID
5. Check Port Setting on Master, Gateway, and Computers

## ModBus Error Codes

1. Check ModBus communication for error codes (see page 9 for ModBus Exception Codes)
2. Check ModBus PDU
3. Check Slave ID
4. Check ModBus Command
5. Check Configuration bits for Holding Register 40001
6. Check Commands and data for Holding Registers 40002 - 40007

## Unit Status Codes

See Codes in this section.

## Unit Status

The Lochinvar Crest boiler or Regent water heater displays a status code on the View Screen to help with troubleshooting. The unit status indicates what the boiler or water heater is actually doing. This state should be compared to the command issued and what is expected. If the unit status does not agree with the command issued, check communication and configuration.

## Crest Only:

### Status Codes (Input Register 30014 or Analog Input AI13)

- 2 = Heat Demand blocked due to high absolute outlet temperature
- 3 = Heat Demand blocked due to high absolute flue temperature
- 4 = Heat Demand blocked due to high absolute Delta T (Outlet - Inlet)
- 7 = Heat Demand blocked due to changed Personality Plug
- 8 = Heat Demand blocked due to Low 24 VAC
- 9 = Outdoor shutdown
- 10 = Block due to switch OFF boiler (ON/OFF of Display)
- 11 = No heat demand requested
- 12 = Block due to line frequency
- 16 = Service function
- 19 = DHW function Storage Tank
- 21 = SH function Heat demand from Room Thermostat
- 22 = SH function Heat demand from Boiler Management System
- 23 = SH function Heat demand from Cascade
- 30 = Heat demand activated by Freeze Protection
- 32 = DHW Pump Delay
- 33 = SH Pump Delay
- 34 = No heat function (after pump delay)
- 40 = Lockout

### Blocking Codes (Input Register 30015 or Analog Input AI14)

- 0 = No blocking
- 5 = Blocking Due to Low 24 VAC Supply
- 6 = Blocking MRHL is open
- 8 = Blocking due to Switched OFF boiler (Display ENTER switch)
- 10 = Blocking due to High Delta T
- 14 = Blocking due to line frequency
- 15 = Blocking due to high flue temperature
- 11 = Blocking due to high outlet water temperature
- 12 = Blocking due to anti-cycling time
- 13 = Blocking due to changed ID Plug
- 7 = Blocking due to high outdoor temperature

# 13 Troubleshooting

## Crest Only:

### Lockout Codes      Description (Input Register 30016 or Analog Input AI15)

**NOTICE**

The lockout code (Input Register 30016) is constantly changing during operation and should not be used for lockout notification until the status code (Input Register 30014) indicates a code of 40.

5	=	Analog to Digital converter input had changed too quickly
7	=	Rapid Temperature Change on Pre-Mix Sensor 2 (S14)
8	=	Rapid Temperature Change on Pre-Mix Sensor 1 (S13)
9	=	Rapid Temperature Change on Pre-Mix Sensor 2 (S12)
10	=	Rapid Temperature Change on Pre-Mix Sensor 1 (S11)
11	=	Analog to Digital converter input is changed too quickly
12	=	Rapid Temperature Change on Flue Sensor (S10)
13	=	Rapid Temperature Change on Outlet Sensor (S9)
15	=	Rapid Temperature Change on System Return Sensor (S7)
16	=	Rapid Temperature Change on System Supply Sensor (S6)
17	=	Rapid Temperature Change on Tank Sensor (S4)
18	=	Rapid Temperature Change on Flue Sensor (S3)
19	=	Rapid Temperature Change on Inlet Sensor (S2)
20	=	Rapid Temperature Change on Outlet Sensor (S1)
25	=	Pre-Mix Sensor 2 (S14)-Short
26	=	Pre-Mix Sensor 1 (S13)-Short
27	=	Pre-Mix Sensor 2 (S12)-Short
28	=	Pre-Mix Sensor 1 (S11)-Short
29	=	Flue Sensor (S10)-Short
30	=	Outlet Sensor (S9) – Short
32	=	System Return Temperature Sensor (S7) – Short
33	=	System Supply Temperature Sensor (S6) – Short
34	=	Tank Sensor (S4) – Short
35	=	Flue Sensor (S3) – Short
36	=	Inlet Sensor – Short
37	=	Outlet Sensor (S1) – Short
38	=	Temperature Measurement Error 2
39	=	Temperature Measurement Error 1
45	=	High temperature differential between S12 and S14
46	=	High temperature differential between S11 and S13
48	=	High temperature differential between S3 and S10
49	=	High temperature differential between S1 and S9
50	=	Internal Error
129	=	Large Pre-Mix Temperature High
130	=	Small Pre-Mix Temperature High
134	=	Louvers Not Open
135	=	Louvers Not Closed
137	=	Large Blower Proving Switch Not Closed
139	=	Large Blower Proving Switch Not Open
140	=	Small Blower Proving Switch Not Open
145	=	Large Blower Proving Switch Not Closed
146	=	Small Blower Proving Switch Not Closed
148	=	Large Blower Proving Switch Not Open
149	=	Air Metering Valve Not Closed / Large Fan Speed Too Low
150	=	Air Metering Valve Not Open / Large Fan Speed Too High
163	=	Wrong Personality Plug
164	=	Flame Current Circuit Failed
166	=	Auto Reset High Limit
167	=	Blocked Drain Switch Open
169	=	Gas Pressure Switch Open

# 13 Troubleshooting *(continued)*

## Crest Only:

### Lockout Codes      Description (Input Register 30016 or Analog Input AI15)

**NOTICE**

The lockout code (Input Register 30016) is constantly changing during operation and should not be used for lockout notification until the status code (Input Register 30014) indicates a code of 40.

170	=	Low Water Cut-Off Open
177	=	Flue Sensor Short
178	=	Flue Sensor Open
179	=	Inlet Sensor Short
180	=	Inlet Sensor Open
192	=	Outlet Sensor Short
193	=	Outlet Sensor Open
201	=	Internal Error
204	=	Internal Error
205	=	Parameters Programmed
206	=	Error while programming Parameters
207	=	Internal Error
228	=	Pre-Mix Sensors Temperature Differential Too High
229	=	Transition Flame / Flame Failure 2
230	=	Fan / Small Fan Speed Low
231	=	Fan / Small Fan Speed High
232	=	Flame Failure 1
233	=	Ignition Failure
235	=	Flue Damper / Small Blower Proving Switch Not Open
236	=	Flue Damper / Small Blower Proving Switch Not Closed
238	=	Air Pressure Switch Open
239	=	Main Flame / Flame 1 Out of Sequence
240	=	External Manual Reset High Limit
241	=	Transition Flame / Flame 2 Out of Sequence
243	=	Transition Gas Valve Relay Failure
244	=	Large Gas Valve Relay Failure
245	=	Small Gas Valve Relay Failure
246	=	Internal Manual Reset High Limit
247	=	High Flue Temperature
253	=	High Combustion Air Temperature
254	=	Display Fault

# 13 Troubleshooting

## Hellcat Only:

### Status Codes (Input Register 30014 or Analog Input AI13)

- 0 = Service Mode
- 2 = Domestic hot water
- 3 = Cascade (DHW)
- 4 = Cascade (CH)
- 5 = BMS 1-10V
- 6 = Central heating
- 10 = Frost protection
- 11 = No demand requested

### Blocking Codes (Input Register 30015 or Analog Input AI14)

The Blocking Code should be interpreted as a binary number. Each bit that is set corresponds to a cause of the blocking. When multiple bits are set, there are multiple reasons for blocking.

- Bit 0 = Not used
- Bit 1 = Jamming prevention of the boiler pump
- Bit 2 = Jamming prevention of the system pump
- Bit 3 = Jamming prevention of the CH pump
- Bit 4 = Jamming prevention of the recirculation pump
- Bit 5 = Jamming prevention of the bypass pump
- Bit 6 = High system supply temperature
- Bit 7 = High system return temperature
- Bit 8 = High flue temperature
- Bit 9 = High tank temperature
- Bit 10 = Anti-cycling
- Bit 11 = Communication error between BIC and CC board
- Bit 12 = Louver
- Bit 13 = High delta T between system supply and system return

#### Example Blocking Codes

Reason	Decimal	Hex	Binary
Louver Proving	4096	1000	1000000000000
Anti-cycling	1024	400	10000000000

#### Example/How to convert:

- 1) Convert number to binary. This conversion can be accomplished through online number based converters.
  - a. For example, a value of 1088 in decimal is equivalent to a value of 10001000000 in binary.
- 2) Count which bit is set going from right to left starting with zero.

a.

Bit 10	Bit 9	Bit 8	Bit 7	Bit 6	Bit 5	Bit 4	Bit 3	Bit 2	Bit 1	Bit 0
1	0	0	0	1	0	0	0	0	0	0

- a. Bits 6 and 10 are set which correspond to blocking on High System Supply Temperature and Anti-cycling

## Hellcat Only:

### Lockout Codes (Input Register 30016 or Analog Input AI15)

- | Lockout Codes | Description   |
|---------------|---|
| 121 =         | High gas pressure switch open while running         |
| 122 =         | Low gas pressure switch open while running          |
| 123 =         | High & low gas pressure switches open while running |
| 124 =         | Blocked drain recycle                               |
| 126 =         | Flue damper recycle                                 |
| 129 =         | Blocked vent recycle                                |
| 160 =         | Gas Valve 1 low power fault                         |
| 161 =         | Gas valve 1 high power fault                        |
| 162 =         | Gas Valve 2 low power fault                         |
| 163 =         | Gas Valve 2 high power fault                        |
| 164 =         | ADC Fault - Outlet Sensor S1                        |
| 165 =         | ADC Fault - Outlet Sensor S9                        |
| 166 =         | ADC Fault - Flue Sensor S3                          |
| 167 =         | ADC Fault - Flue Sensor S9                          |
| 168 =         | ADC Fault - Premix Sensor S11                       |
| 169 =         | ADC Fault - Premix Sensor S13                       |
| 170 =         | ADC Fault - 24V fault                               |
| 171 =         | ADC Fault - 5V fault                                |
| 176 =         | Internal sensing fault                              |
| 177 =         | Internal sensing fault                              |
| 189 =         | Flue Temp Maximum                                   |
| 190 =         | Outlet Temp MRHL                                    |
| 191 =         | Outlet Temp ARHL                                    |
| 192 =         | Outlet Water sensor shorted                         |
| 193 =         | Outlet Water sensor opened                          |
| 194 =         | Inlet Water sensor shorted                          |
| 195 =         | Inlet Water sensor opened                           |
| 197 =         | Flue sensor shorted                                 |
| 198 =         | Flue sensor opened                                  |
| 199 =         | LWCO  |
| 204 =         | CRC Error   |
| 205 =         | EEPROM Programmed                                   |
| 206 =         | Programming Error                                   |
| 207 =         | EEPROM Write Error                                  |
| 221 =         | High gas pressure switch open during purge          |
| 222 =         | Low gas pressure switch open during purge           |
| 223 =         | High and Low gas pressure switch open during purge  |
| 224 =         | Blocked drain switch open during purge              |
| 226 =         | Flue damper proving switch open during purge        |
| 227 =         | Internal Fault                                      |
| 229 =         | Blocked Vent switch open during purge               |
| 230 =         | Fan speed low                                       |
| 231 =         | Fan speed high                                      |
| 232 =         | Flame fail running                                  |
| 233 =         | Flame fail ignition                                 |
| 237 =         | Flame out-of-sequence                               |
| 239 =         | External MRHL                                       |

# 13 Troubleshooting *(continued)*

## **Hellcat Only:**

### **Lockout Codes Description Continued**

#### **(Input Register 30016 or Analog Input AI15)**

242 =	Combustion Feedback during rest
243 =	Combustion Feedback during purge
246 =	Proof-of-closure feedback fault - closed
247 =	Proof-of-closure feedback fault - open
248 =	Air Proving Switch fault - closed
249 =	Air Proving Switch fault - open
250 =	Too many Resets
251 =	Combustion Feedback during run
254 =	Too many Resets

# 13 Troubleshooting

## Regent Only:

### Status Codes (Input Register 30014 or Analog Input AI13)

- 0 = Service Mode
- 2 = Domestic hot water (DHW1)
- 4 = Cascade
- 5 = BMS 1-10V
- 10 = Frost protection
- 11 = No demand requested

### Blocking Codes (Input Register 30015 or Analog Input AI14)

The Blocking Code should be interpreted as a binary number. Each bit that is set corresponds to a cause of the blocking. When multiple bits are set, there are multiple reasons for blocking.

- Bit 0 = Not used
- Bit 1 = Jamming prevention of the internal circulation pump
- Bit 2 = Not used
- Bit 3 = Jamming prevention of the cascade valve
- Bit 4 = Jamming prevention of the building recirculation pump
- Bit 5 = Not used
- Bit 6 = High system supply temperature
- Bit 7 = High system return temperature
- Bit 8 = High flue temperature
- Bit 9 = Not used
- Bit 10 = Not used
- Bit 11 = Communication error between BIC and CC board
- Bit 12 = Not used
- Bit 13 = High delta T between system supply and system return

#### Example Blocking Codes

Reason	Decimal	Hex	Binary
High Flue Temp	256	100	100000000

#### Example/How to convert:

- 1) Convert number to binary. This conversion can be accomplished through online number based converters.
  - For example, a value of 2112 in decimal is equivalent to a value of 100001000000 in binary.
- 2) Count which bit is set going from right to left starting with zero.

a.

Bit 11	Bit 10	Bit 9	Bit 8	Bit 7	Bit 6	Bit 5	Bit 4	Bit 3	Bit 2	Bit 1	Bit 0
1	0	0	0	0	1	0	0	0	0	0	0

- b. Bits 6 and 11 are set which correspond to blocking on High System Supply Temperature and Communication error between DIC and CC

## Regent Only:

### Lockout Codes (Input Register 30016 or Analog Input AI15)

- | Lockout Codes | Description   |
|---------------|---|
| 121 =         | High gas pressure switch open while running         |
| 122 =         | Low gas pressure switch open while running          |
| 123 =         | High & low gas pressure switches open while running |
| 124 =         | Blocked drain recycle                               |
| 126 =         | Flue damper recycle                                 |
| 129 =         | Blocked vent recycle                                |
| 160 =         | Gas Valve 1 low power fault                         |
| 161 =         | Gas valve 1 high power fault                        |
| 162 =         | Gas Valve 2 low power fault                         |
| 163 =         | Gas Valve 2 high power fault                        |
| 164 =         | ADC Fault - Outlet Sensor S1                        |
| 165 =         | ADC Fault - Outlet Sensor S9                        |
| 166 =         | ADC Fault - Flue Sensor S3                          |
| 167 =         | ADC Fault - Flue Sensor S9                          |
| 168 =         | ADC Fault - Premix Sensor S11                       |
| 169 =         | ADC Fault - Premix Sensor S13                       |
| 170 =         | ADC Fault - 24V fault                               |
| 171 =         | ADC Fault - 5V fault                                |
| 176 =         | Internal sensing fault                              |
| 177 =         | Internal sensing fault                              |
| 189 =         | Flue Temp Maximum                                   |
| 190 =         | Outlet Temp MRHL                                    |
| 191 =         | Outlet Temp ARHL                                    |
| 192 =         | Outlet Water sensor shorted                         |
| 193 =         | Outlet Water sensor opened                          |
| 194 =         | Inlet Water sensor shorted                          |
| 195 =         | Inlet Water sensor opened                           |
| 197 =         | Flue sensor shorted                                 |
| 198 =         | Flue sensor opened                                  |
| 199 =         | LWCO  |
| 204 =         | CRC Error   |
| 205 =         | EEPROM Programmed                                   |
| 206 =         | Programming Error                                   |
| 207 =         | EEPROM Write Error                                  |
| 221 =         | High gas pressure switch open                       |
| 222 =         | Low gas pressure switch open                        |
| 223 =         | High and Low gas pressure switch open               |
| 224 =         | Blocked drain switch open during purge              |
| 226 =         | Flue damper proving switch open during purge        |
| 227 =         | Internal Fault                                      |
| 229 =         | Blocked Vent switch open during purge               |
| 230 =         | Fan speed low                                       |
| 231 =         | Fan speed high                                      |
| 232 =         | Flame fail running                                  |
| 233 =         | Flame fail ignition                                 |
| 237 =         | Flame out-of-sequence                               |
| 239 =         | HEX Door Temperature Switch open / MRHL             |

# 13 Troubleshooting

## Regent Only:

### Lockout Codes Description Continued (Input Register 30016 or Analog Input AI15)

- 242 = Combustion Feedback during rest
- 243 = Combustion Feedback during purge
- 246 = Proof-of-closure feedback fault - closed
- 247 = Proof-of-closure feedback fault - open
- 248 = Air Proving Switch fault - closed
- 249 = Air Proving Switch fault - open
- 250 = Too many Resets
- 251 = Combustion Feedback during run
- 254 = Too many Resets
- 252 = Flow Switch / LWCO open for too long
- 253 = Flow Switch / LWCO open for too long while running

---

# NOTES

---

# NOTES

---

# NOTES

**Revision Notes:** Revision A (ECO #C08179) initial release.

Revision B (ECO C08542) reflects edits made (pages 7, 8 and 18) due to changes made by SIT.

Revision C (ECO C10325) reflects the addition of version 4, software update (page 8).

Revision D (ECO C10391) reflects the update of ladder and wiring diagrams on pages 22 and 23.

Revision E (ECO C11613) reflects the addition of the lockout code notice on page 19 (R05772) and the addition of models 4.0 and 5.0.

Revision F (ECO C17106) reflects the addition of models .75 - 1.25.

Revision G (ECO C17530) reflects the addition of BACnet information (sections and images).

Revision H (Change #500001029) reflects the removal of the Wiring and Ladder Diagrams.

Revision J (PCP #3000003566 / CN #500003622) reflects the addition of the 6.0 Btu Model.

Revision K (PCP# 3000007541 / CN# 500007580) reflects the addition of references to A+ and B- on page 13.

Revision L (PCP# 3000008406 / CN# 500008361) reflects an update to the addressing information of BACnet configuration on page 9.

Revision M (PCP# 3000025102 / CN# 500014948) reflects the addition of Models 2501 - 6001.

Revision N (PCP #3000045243 / CN #500032780) reflects Fahrenheit and Celsius enhancement additions on page 9.

Revision P (PCP #3000052880 / CN #500039780) reflects an update to the analog values on page 12 and the object IDs on page 19.

Revision R (PCP #3000053857 / CN #500040433) reflects the addition of FCB1000-6000.

Revision T (PCP #3000058260 / CN #500044453) reflects the addition of AI code 11.

Revision U (PCP #3000059661 / CN #500045753) reflects an update to specific model information throughout.

Revision V (PCP #3000061132 / CN #500047044) reflects an update to the blocking codes on page 29.

Revision W (PCP #3000063393 / CN #500049219) reflects updated codes on page 30.

Regent X (PCP #3000063393 / CN #500056684) reflects the addition of IWH models.